



Tractors

AXION

870 850 830 810 800

**CLAAS**





AXION 870-800.  
Speaks for itself.

AXION 870-800



Impressive in every way.

The AXION 800 in the 200 to 300 hp class offers an outstanding level of driving comfort and ease of operation that makes long working days seem short.

**More of everything.**

- More help: the self-learning operator assistance system CEMOS makes your job so much easier
- More flexibility: with CEBIS you can view two cameras and control ISOBUS implements
- More pressure: the 205 l/min hydraulic circuit
- More efficiency: the engine speed limiter reduces fuel consumption
- More accuracy: a press of the button is all it takes to switch on the rear PTO and then activate the engine speed memory
- More comfort: a leather steering wheel, hands-free system and rear-opening roof hatch make for a more enjoyable working environment



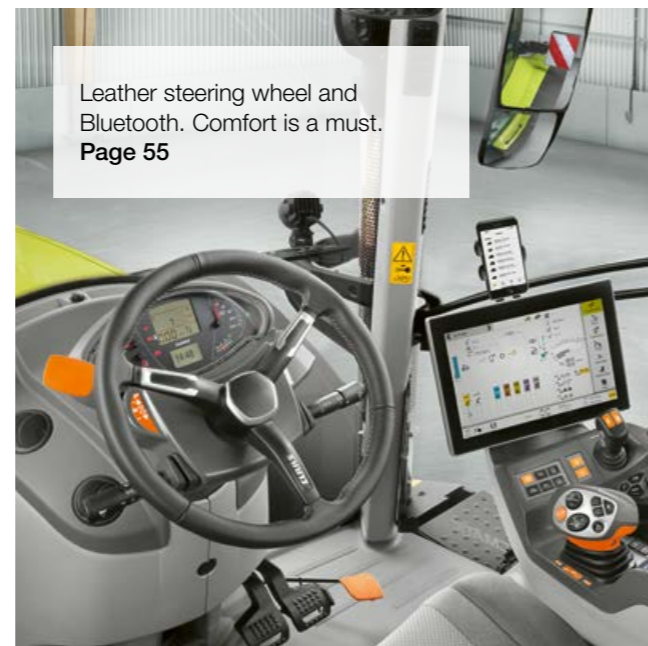
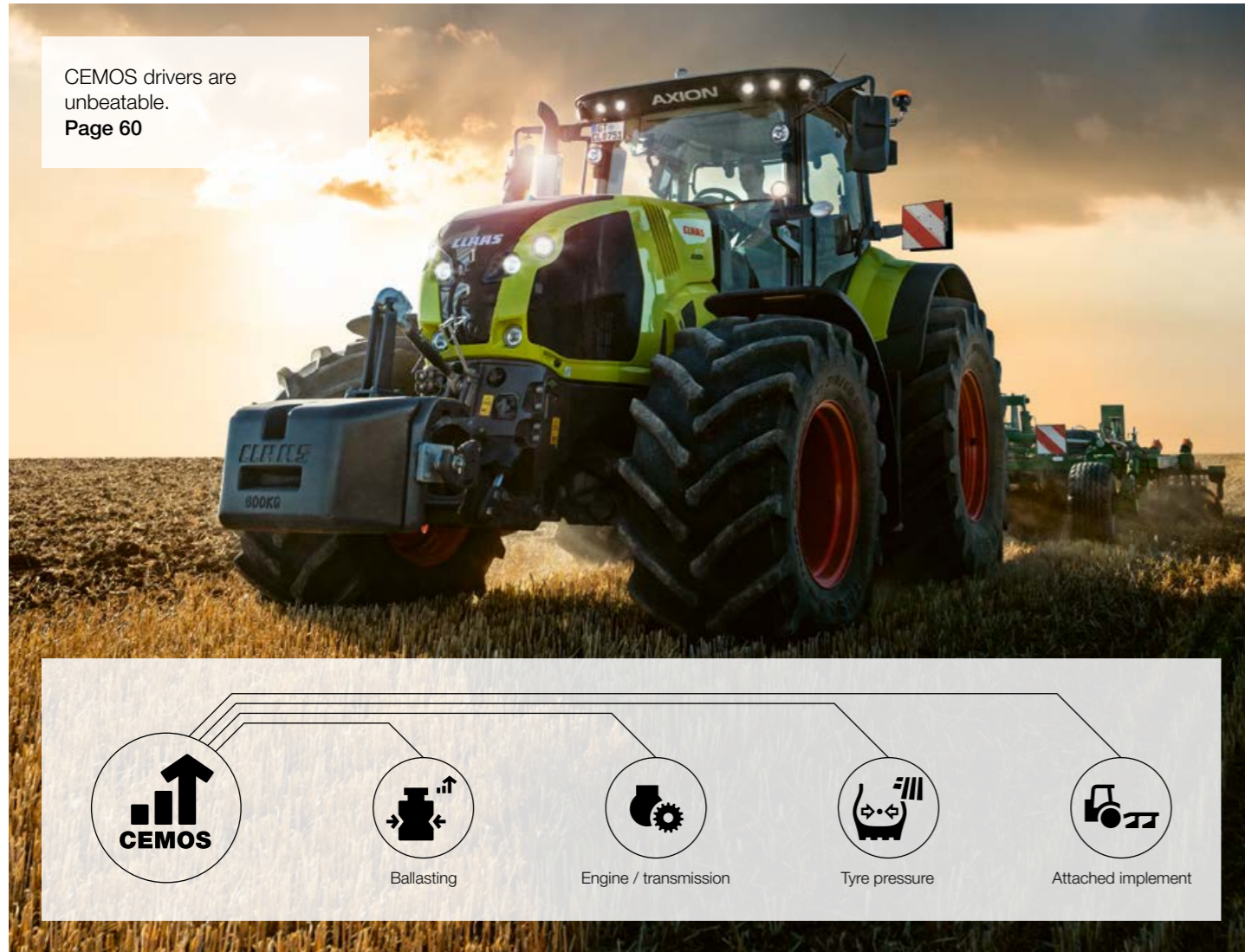

<b>CEMOS for tractors</b>	<b>6</b>
<b>CLAAS POWER SYSTEMS</b>	<b>8</b>
Engine	10
CMATIC	12
HEXASHIFT	18
Construction	24
Safety and manoeuvrability	28
PTO	30
Hydraulics	32
Rear linkage	34
Front linkage	36
<b>Cab and comfort</b>	<b>38</b>
Versions	40
CEBIS	42
CIS+	48
CIS	50
CIS displays	52
Comfort	54
<b>Operator assistance systems and data management</b>	<b>58</b>
CEMOS	60
CSM headland management	62
GPS PILOT CEMIS 1200	64
GPS PILOT CEMIS 1200, ISOBUS functions	66
Data management	68
Maintenance	70
CLAAS Service & Parts	72
Features	74
Technical data	75

More innovation: more details here. [axion800.claas.com](http://axion800.claas.com)



Scan me.



# CEMOS drivers are unbeatable.



## What is CEMOS?

Think of CEMOS as your on-board CLAAS advisor, there to assist you with your daily work. The system suggests setting values and helps the driver continually adjust the machine to the field conditions. CEMOS takes the hassle out of settings and quickly helps the driver optimise machine performance.

## The advantages of CEMOS.

- Reduces tyre wear
- Reduces soil compaction by optimising tyre pressure
- Reduces operating costs by increasing work rates
- Utilises the full potential of the machine
- Reduces implement wear (implement assistant for ploughs and DISCO disc mowers)
- Improves the carbon footprint of your farm

Tested, certified and awarded the "DLG-approved" quality seal by independent test institute the DLG (German Agricultural Society):

- Up to 16.3% higher work rate (ha/h)
- Up to 16.8% lower fuel consumption (l/ha)
- Eight out of ten test participants managed to reduce their fuel consumption while at the same time increasing their work rate

CEMOS drivers are unbeatable.



More information about new CEMOS features and the CEMOS DLG test. [ceмос.claas.com](https://ceмос.claas.com)



Scan me.



Our drive system: the perfect interplay between optimal components.

Your CLAAS machine is much more than the sum of its individual parts. Top performance is only possible when all parts are ideally matched and work together optimally.

In CLAAS POWER SYSTEMS (CPS), we have brought together top-quality components to create an intelligent drive system that sets new standards. Full engine output only when you need it. Drives that are suited to the way your machines are used. Fuel-saving technology which quickly pays off.

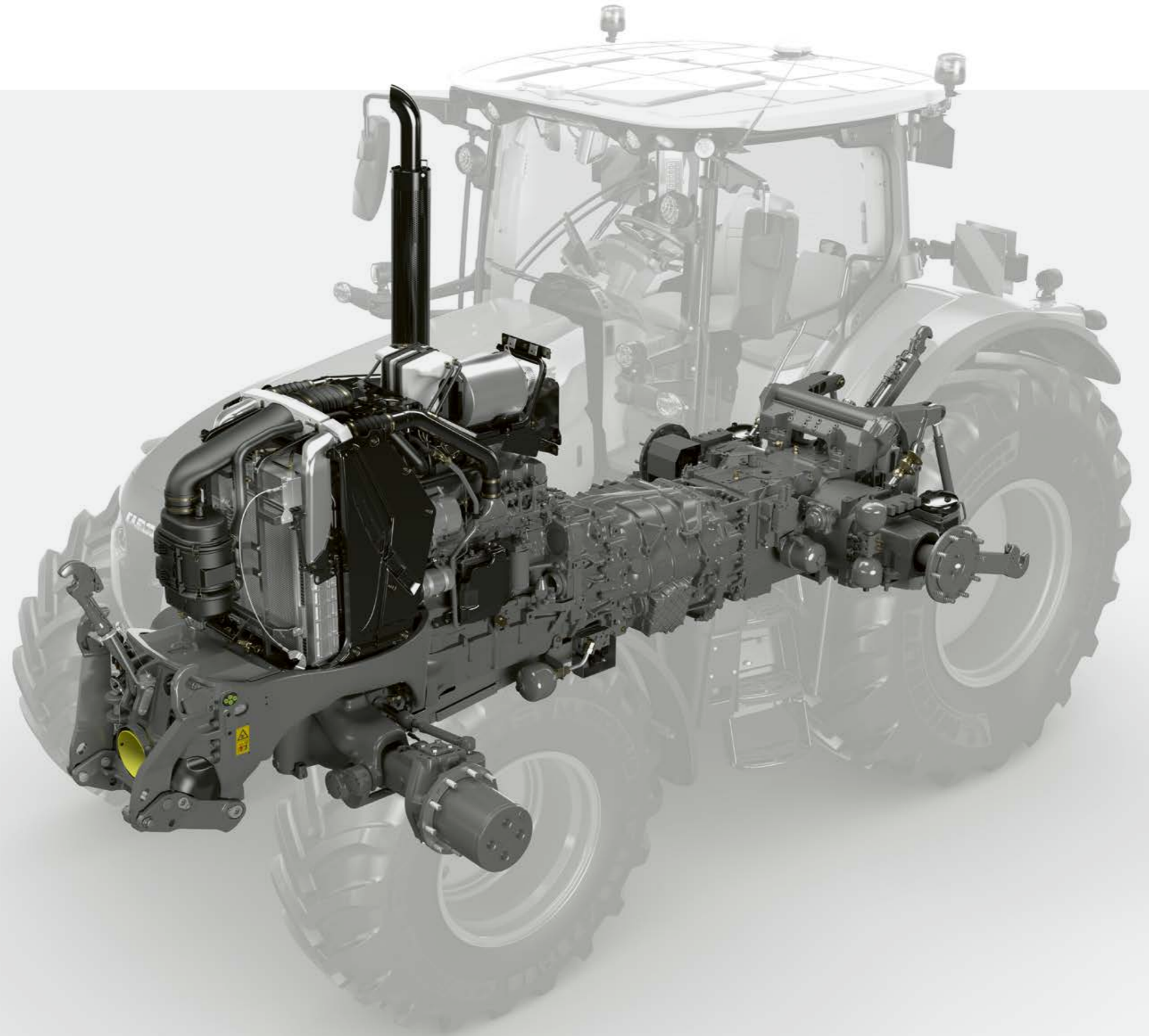



## Strong at heart.

A 6-cylinder, 6.7 litre FPT (Fiat Powertrain Technologies) NEF 6 engine gets to work under a one-piece bonnet. The engine meets the requirements of the Stage V emissions standard by incorporating exhaust gas aftertreatment with urea. It uses the latest common rail 4-valve technology, charge-air cooling and a variable geometry turbo (VGT).

## Constant output.

The CLAAS-specific engine performance curve provides full torque in a wide engine speed range, guaranteeing constant output and power delivery when they are needed. This makes it easy to save fuel while working at a low engine speed and maximum torque with the ECO PTO, or to work at rated speed with a full reserve. Two engine idling speeds (650 and 800 rpm) with automatic adjustment reduce stationary fuel consumption.

## Variable turbo.

The VGT turbo delivers optimum charge-air pressure at any engine speed. It adjusts to load and engine speed, making 70% of maximum torque available even when idling. Optimised combustion means low fuel consumption and maximum performance.

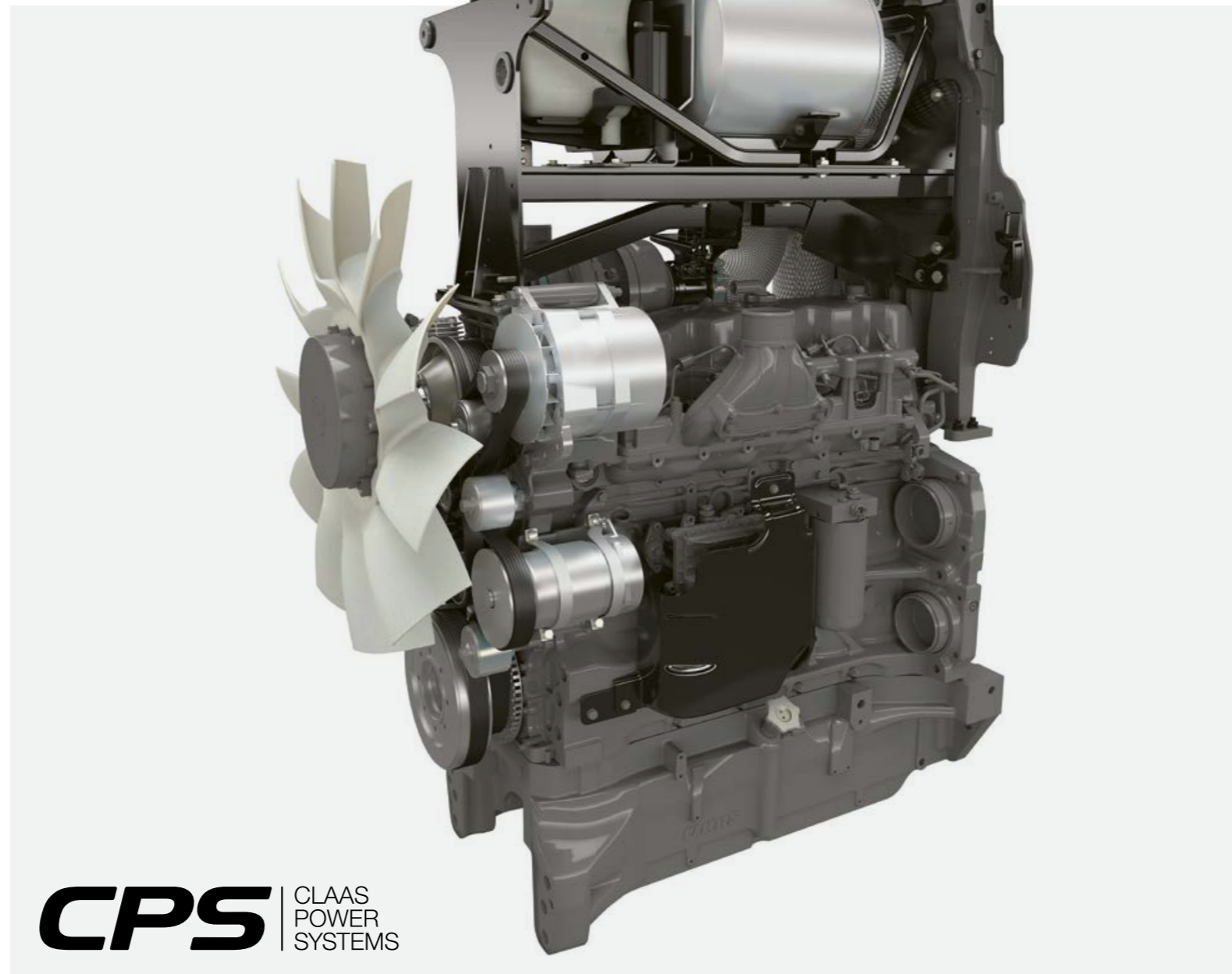

**CPS** | CLAAS  
POWER  
SYSTEMS

## AXION 870 CMATIC.

The AXION 870 CMATIC delivers up to 295 hp thanks to the intelligent CLAAS POWER MANAGEMENT (CPM) electronic control system. Additional boost power is available for PTO work from 7 km/h, for transport operations and also for the fan drive, significantly increasing the performance and versatility of the AXION 870 CMATIC.

AXION <sup>1</sup>	Torque (Nm)	Maximum output (hp) ECE R 120
870	1276 <sup>2</sup>	295 <sup>2</sup>
850	1132	264
830	1016	235
810	941	215
800	896	205

<sup>1</sup> Some models are not available in all countries. Please refer to your CLAAS dealer's price list.

<sup>2</sup> Torque and maximum output with CPM (CLAAS POWER MANAGEMENT).



## Stage V thanks to DOC and SCRoF.

When designing the AXION 800 series, we considered all the components required for exhaust gas aftertreatment from the outset. Full visibility and accessibility are therefore guaranteed. The diesel oxidation catalytic converter (DOC) is positioned under the bonnet immediately behind the turbocharger because it needs high exhaust temperatures to produce an optimum reaction. The Selective Catalytic Reduction on Filter (SCRoF) is an integral part of the exhaust system and is located on the right-hand side of the tractor.

## Visctronic – efficient fan control.

The electronic Visctronic fan control allows the fan speed to be precisely adjusted to the load and engine temperature, ensuring that the engine can always be run at an ideal temperature. The reduced fan speed lowers the noise level and saves valuable fuel with no unnecessary impact on output, which can then be converted into tractive power.



# CLAAS CMATIC. Continuously variable.

- Mechanical power flow from the engine
- Hydraulic power flow
- Combined power flow  
(mechanical + hydraulic to transmission output)

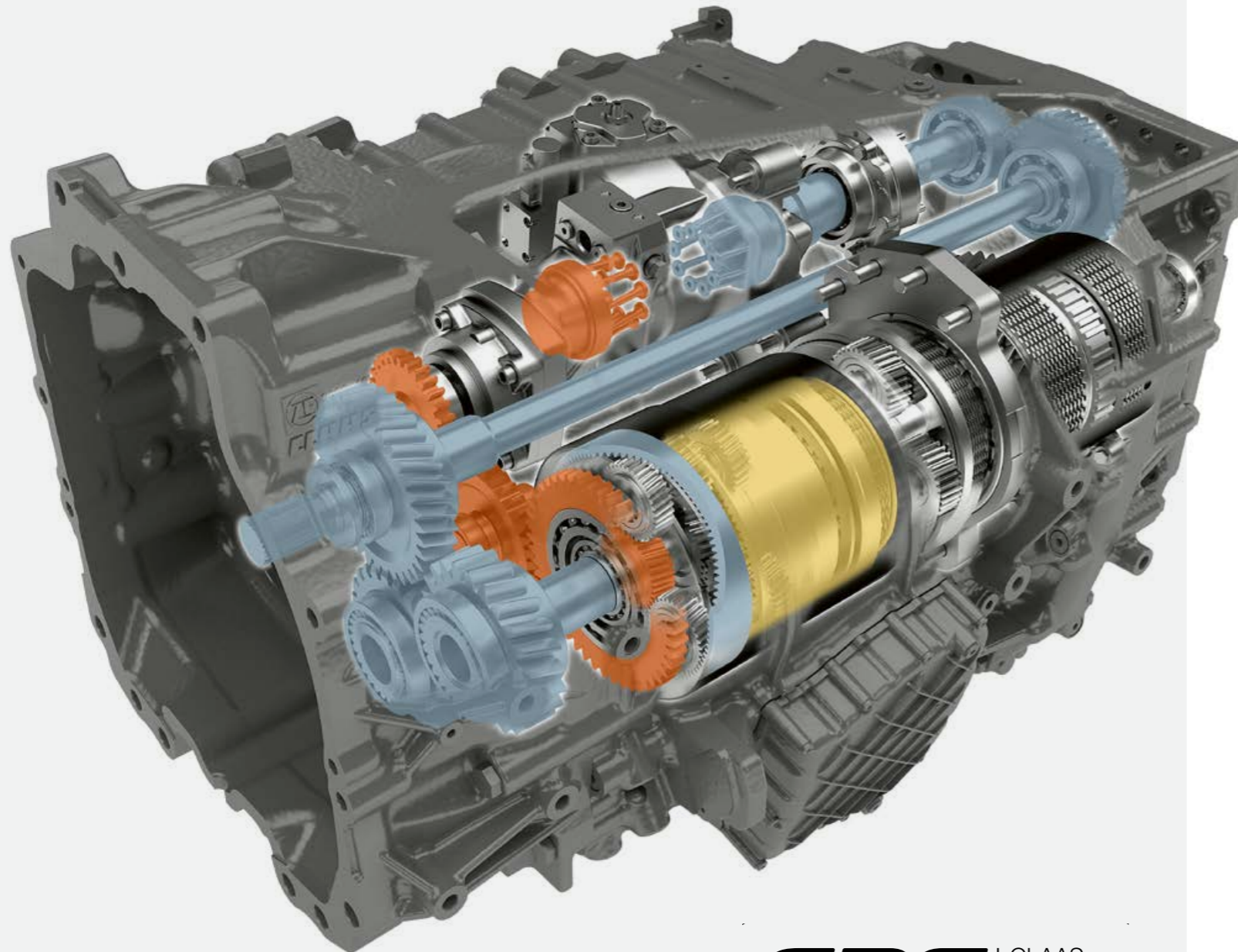

**CPS** | CLAAS  
POWER  
SYSTEMS



## Efficient and user-friendly.

CMATIC is the name of the continuously variable transmission technology used in CLAAS tractors. In the AXION 800 series a ZF Terramatic transmission provides efficient conversion of engine power. In this split-power, continuously variable transmission, the four mechanical ranges are automatically selected by multidisc clutches. There is no need to shift between ranges manually.

The high mechanical component in the power transmission provides outstanding efficiency and low fuel consumption in every speed range.

## Superior transmission control.

Powerful acceleration, smooth deceleration and a fast response to changes in load: CMATIC powertrain management shows its maturity in all conditions and for every task. Stay relaxed and focused throughout the working day so you can concentrate on more important things – CMATIC does the rest for you.

## Exploiting real potential.

The available drive power can be used effectively at speeds from 0.05 to 50 km/h. The high level of mechanical power transmission also delivers outstanding driving force in reverse. What's more, every gear ratio can be used at every engine speed, giving AXION 870-800 tractors enormous potential for use all year round.

With engine speeds of 1,600 rpm at a top speed of 50 km/h and 1,300 rpm at 40 km/h, AXION 870-810 tractors also demonstrate their capabilities in transport operations. If the accelerator is not depressed, the transmission is in powered zero mode and maintains its position without creeping or rolling. This means that the tractor can start up safely and easily at steep field entrances or road junctions, even with a full load.





Engine droop setting for "Eco" and "Power", and the engine speed memory

### Engine droop at the push of a button.

The engine droop value can be used for quick and easy regulation of the engine speed under full load. The CEBIS or CIS terminal clearly displays the engine speed at which the transmission reduces the speed.

When a constant engine speed is activated, i.e. during PTO work, the driver can specify a different droop setting, typically one that matches the engine speed to the required PTO shaft speed.

Two engine droop values can be saved in accelerator pedal and drivestick mode. They can be retrieved by the quick-access facility using the F buttons. With these "Eco" and "Power" values, the droop can be rapidly adjusted to the task in hand, e.g. when moving from road to field. The engine droop for the engine speed memory is set separately.



### Simple, straightforward operation.

The CMATIC transmission has three operating modes: accelerator pedal, drivestick and manual mode.

In the first two modes, forward speed can be controlled by the accelerator pedal or drivestick. The engine speed and transmission ratio are adjusted automatically – for optimum efficiency and optimised fuel consumption. In manual mode, the driver chooses the engine speed and transmission ratio. Automatic engine and transmission control is disabled.

### Accelerator pedal or drivestick.

You can switch between accelerator pedal and drivestick mode while the tractor is moving by pressing a button on the armrest. The active mode is displayed in CEBIS or CIS.



The drive mode is displayed in CEBIS. On the move, you can switch between drivestick and accelerator pedal mode at the press of a button.



# CMATIC. No need to stop.



## Tailor-made speed ranges.

With the CMATIC transmission, three speed ranges can be pre-selected in both directions of travel. The active range is displayed in CEBIS or CIS and can be changed while the tractor is in motion using two buttons. The lower the maximum preset value for the range, the more accurately the forward speed can be controlled.

A cruise control speed can be saved for all the ranges while the tractor is moving by pressing the button on the drivestick. The cruise control speeds can also be pre-set on the CEBIS or CIS terminal.

CMATIC allows drivers to create their own profiles according to the job in hand. Intelligent CMATIC transmission technology enables you to use the full power of your AXION economically and productively – with maximum operator comfort.

## Stopping power.

The CMATIC transmission offers different ways of adapting braking to the job in hand.

### Increase the engine braking effect:

When the accelerator pedal is released and the multifunction control lever is pulled back, the transmission ratio is reduced, causing the engine speed to increase. The optional engine retarder also comes into play. It engages automatically when it is needed and increases the engine braking effect by up to 2.5 times. This reduces brake wear.

### Anti-jackknife brake:

When the trailer is braked with the service brake, you can accelerate at the same time using the accelerator pedal or by pressing the multifunction control lever. This maintains the distance between the tractor and trailer on steep hills and increases safety. These functions can be used whether the tractor is stationary or moving.

CIS+ operation

- 1 Change range
- 2 Activate cruise control





# HEXASHIFT

for maximum efficiency.

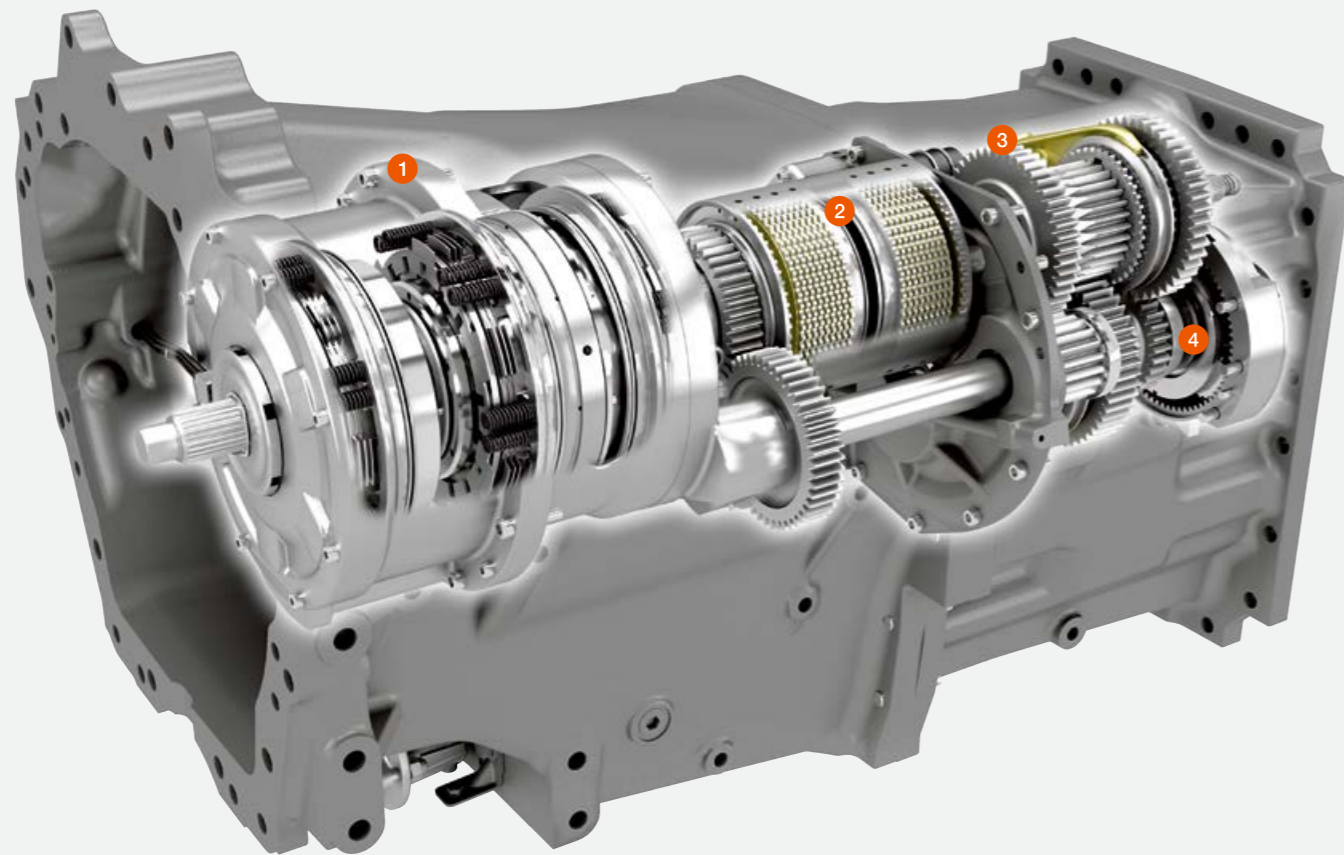

- 1 HEXASHIFT 6-speed powershift module
- 2 REVERSHIFT electronic clutchless reverser
- 3 Electrohydraulically actuated 4-speed range shift
- 4 Optional creep gears



## The HEXASHIFT powershift transmission from CLAAS.

With HEXASHIFT you can shift effortlessly through all six powershift speeds and the four automatic ranges using your fingertips, or you can shift automatically using the HEXACTIV auto-shift function.

HEXASHIFT is available in two different versions:

- ECO 40 km/h at 1,950 rpm
- ECO 50 km/h at 1,950 rpm

Overlapping powershift speeds allow the full output potential of the engine to be utilised. This overlap also provides smooth range shifting on the road.

HEXASHIFT: 24 gears for optimum gear spacing

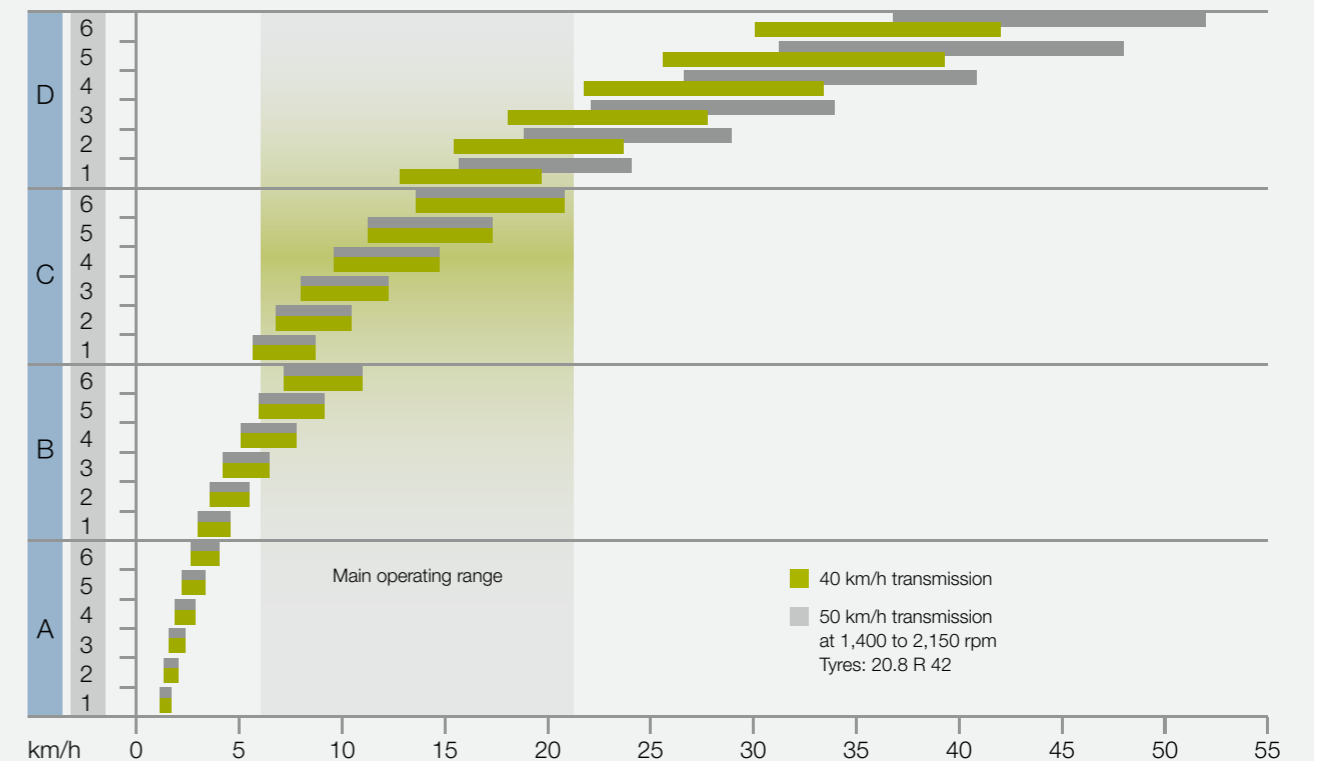

## Clear benefits.

- No need to use the clutch when changing range
- Good gear spacing in all ranges
- Twelve gears in the main operating range
- Fully automatic shifting with HEXACTIV
- HEXACTIV auto-shift function with cruise control
- Disable cruise control and engine speed memory using the throttle pedal
- Excellent efficiency in the field and on the road for low fuel consumption
- Creep gear options down to 450 m/h
- Convenient adjustment options with CIS or CEBIS
- High operating comfort with the DRIVESTICK or CMOTION
- CLAAS powertrain management for smooth changes in range and powershift operations
- REVERSHIFT clutchless reverser with electronic parking brake
- SMART STOP: stop with the brake pedal without using the clutch
- REVERSHIFT reversing function on the ELECTROPILOT four-way control lever



# HEXASHIFT.

Always in the right gear.

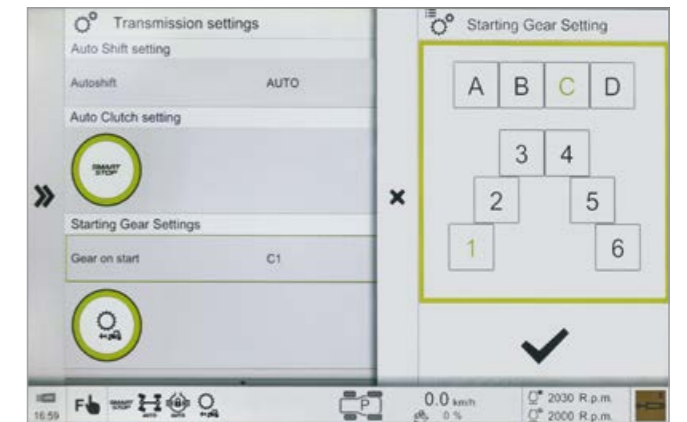
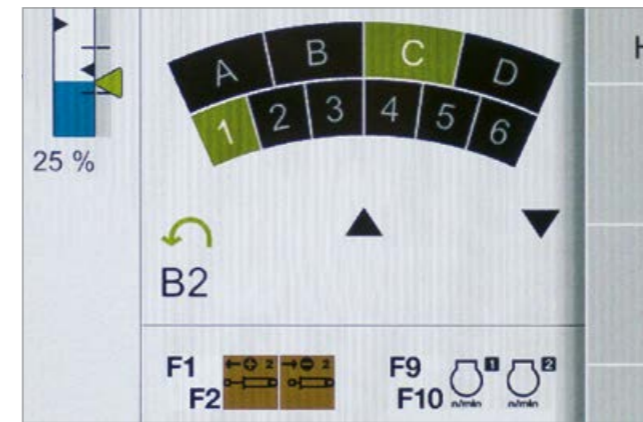

## Intelligent transmission settings.

When using the clutchless reverser, you can even change gear automatically when you want the forward speed to be different from the reverse speed. At the headland, you can also engage a pre-selected gear simply by pressing a button. This means that you are always moving at the same speed on the headland. The aggressiveness of the REVERSHIFT clutchless reverser is also adjustable in nine steps (-4 to +4), providing optimum ride comfort in all situations.

## HEXACTIV start-up and approach gears.

The start-up gear engaged when starting the engine is freely selectable between A1 and D1. The specified start-up gear is engaged every time you start the engine. A separate approach gear can also be selected when operating with the HEXACTIV auto-shift function activated. This gear is automatically engaged as soon as the tractor comes to a standstill.

## Automatic transmission control.

There's no need to move through every gear (as in a conventional powershift transmission) when shifting between ranges – the HEXASHIFT transmission automatically selects the most appropriate gear depending on forward speed and load, regardless of whether you are driving manually or automatically. If you press the clutch in range D, the transmission automatically adjusts the powershift speed when the clutch is re-engaged. This can be very useful, e.g. when approaching a junction.

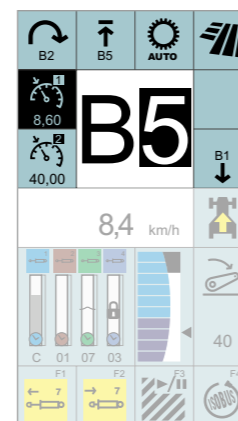

Intelligent gear selection on the A-pillar display in the CIS version

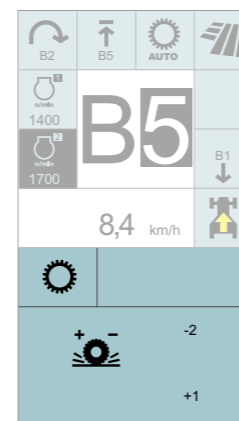

REVERSHIFT progressivity in CIS

## SMART STOP and cruise control.

With the SMART STOP function, AXION 800 tractors can be brought to a standstill by pressing the brake, without needing to use the clutch pedal. This lightens the driver's workload considerably, especially during tasks which involve a lot of stopping and starting. SMART STOP is easily activated in CEBIS or CIS. The HEXACTIV auto-shift function can be equipped with a cruise control function. Instead of a fixed engine speed, a target forward speed is specified by pressing a button and the tractor maintains this speed by adjusting the engine speed and gear ratio.

## Engine speed limiter.

The engine speed limiter is a great help when it comes to saving fuel. Simply set the maximum engine speed in advance and then you can focus fully on your work. The engine maintains the set speed regardless of how hard you depress the accelerator. This allows you to cut fuel consumption significantly.



# HEXASHIFT. HEXACTIV changes gear for you.



Manual shifting	Driving strategies	Mode	Shifting
	<p><b>Manual shifting in field mode</b></p>		<ul style="list-style-type: none"> <li>– Range shifting (A-D) by pressing the DRIVE-STICK or CMOTION through the stop</li> <li>– Powershift shifting (1-6) by tapping the DRIVESTICK or CMOTION</li> </ul>
<p><b>Manual shifting in transport mode</b></p>		<ul style="list-style-type: none"> <li>– Shift through all 24 gears (A1-D6) by tapping the DRIVESTICK or CMOTION</li> </ul>	

HEXACTIV auto-shift function	Driving strategies	Mode	Shifting
	<p><b>Automatic shifting in field mode</b></p>	 	<ul style="list-style-type: none"> <li>– Range shifting (A-D) by pressing the DRIVE-STICK or CMOTION through the stop</li> <li>– Automatic powershift shifting (1-6)</li> </ul>
<p><b>Automatic shifting in transport mode</b></p>	 	<ul style="list-style-type: none"> <li>– Shift all 24 gears (A1-D6) automatically</li> </ul>	

## HEXACTIV auto-shift function.

Because you've got more important things to do, you can leave HEXACTIV to change gear automatically. You can configure the HEXACTIV auto-shift function with a wide range of well-designed functions to suit your preferences and the job in hand.

There are three auto-shift modes to choose from in CEBIS or CIS:

- Fully automatic: HEXACTIV shifts for variations in engine speed depending on engine load, vehicle speed and the driver's preference / accelerator position
- PTO mode: HEXACTIV shifts so as to ensure that the engine speed / PTO speed remain as constant as possible
- Manual mode: HEXACTIV shifts according to a fixed engine speed which is programmable by the driver

## Setting the three modes in the colour CIS:

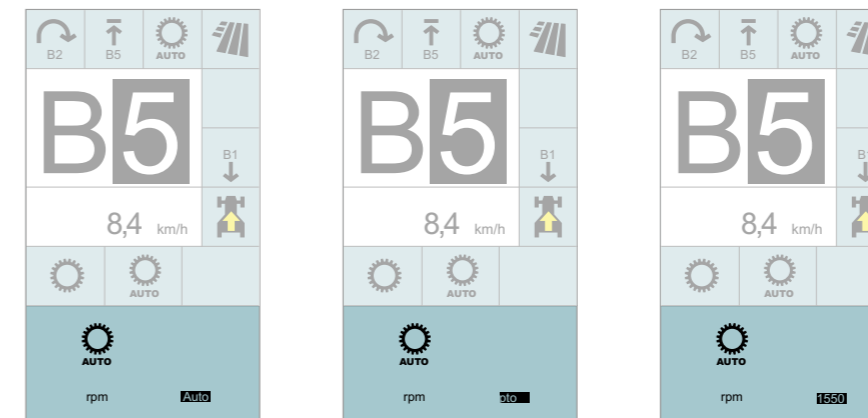

Fully automatic mode

PTO mode

Manual mode



Stable and manoeuvrable.  
Immense tractive power.



Slim waist for tight turns.

CLAAS has drawn on experience gained in developing standard tractors up to 400 hp or more to create a perfectly coordinated solution for the AXION 800 series – for endurance work under extremely challenging conditions. The engine is housed in a strong frame section with an integrated engine oil sump which absorbs all the forces associated with the front linkage and front chassis.

The specially shaped front chassis provides plenty of space for the radiators immediately above the front axle. In front and behind it is designed to be very narrow, like a wasp waist. This gives an excellent steering lock angle and small turning circles.

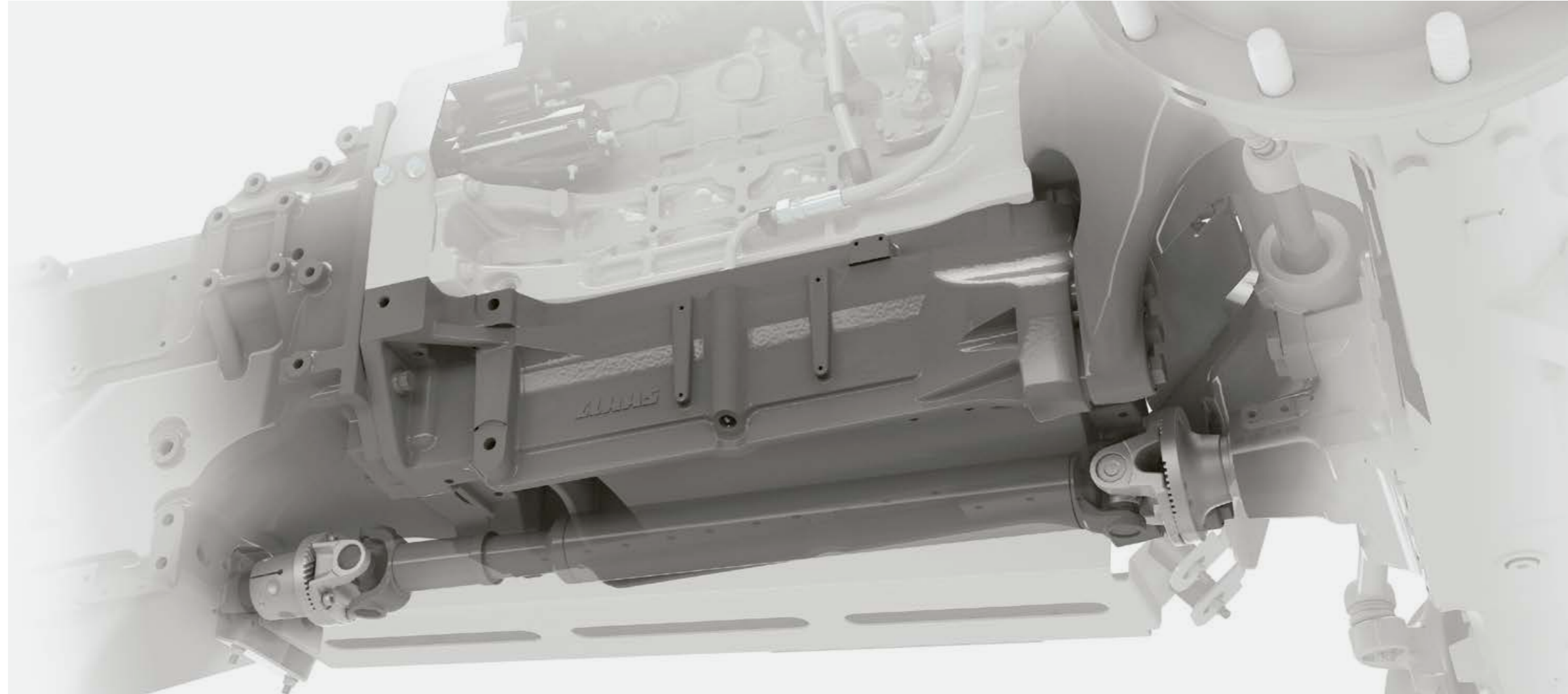

In practice, this means:

- Maximum stability even when using heavy front-mounted implements
- Excellent steering lock angle for maximum manoeuvrability
- Optimum access to the entire engine compartment and all maintenance points

Key benefits:

**Long wheelbase:**

- High ride comfort
- Directional stability
- Higher tractive power due to better weight distribution
- Good, safe road handling
- Higher lifting power due to better weight distribution



**Short overall length:**

- Good manoeuvrability
- Short trailer combination on the road
- Good visibility
- Good guidance of front-mounted implements



**Good power to weight ratio:**

- Optimises fuel consumption
- Low ground pressure during tillage
- Dynamic road transport
- 50:50 weight distribution front / rear





Fully balanced.

With so many front and rear axle ballast options, the AXION can easily be adapted to every application. Its full performance potential can then be exploited without unnecessary losses. If you need to carry out heavy work at low speeds, the ballasting on the AXION can easily be increased. Weight that is no longer required can be removed just as easily.

Several factory-fitted combinations are available for flexible ballasting on the fixed weight carrier or front linkage.

Wheel weights for rear axle, in kg

38" rim	42" rim
2 x 244	2 x 220
2 x 322	2 x 409



Power and endurance.

The rear tyres on AXION 800 tractors can be up to 2.05 m in diameter. Tyres up to 1.60 m diameter are used on the front axle. The numerous tyre options make the AXION capable of any type of work. Even with the biggest tyres (900/60 R 38) the tractor has an external width of less than 3.0 m, making it flexible on the road and gentle on the field.

AXION footprint

- AXION 870-810 CMATIC and 850-830 HEXASHIFT:
  - Rear tyres up to 900 mm wide and 2.05 m in diameter
- AXION 810 / 800 HEXASHIFT:
  - Rear tyres up to 710 mm wide and 1.95 m in diameter
- Dual tyres<sup>1</sup> for AXION 870 / 850:
  - Flange-mounted on quick-release axle even for heavy traction work
  - Dual tyres up to 650 mm wide

<sup>1</sup> Dual tyres are not available in all countries. Please refer to your dealer's price list.



CTIC tyre pressure adjustment system.

The right tyre pressure protects the soil and benefits the yield in the long term. But it offers other economical advantages too, such as increased tractive power, reduced fuel consumption and low tyre wear. The air valves are integrated into the patented rotary transmitters to ensure direct high-precision tyre pressure measurement and control at the wheel. The tyre pressure is continually monitored and automatically adjusted.

In the basic version, the CTIC is supplied by the tractor compressor. The CTIC 2800 version has its own screw compressor with an airflow rate of 2,800 l/min. We recommend the CTIC 2800 if you frequently switch from field to road or want to adjust the tyre pressure to suit the trailed implement.







### Trailer brake system.

The AXION can be fitted with a pneumatic and a hydraulic trailer brake system in order to meet country-specific requirements. Both systems can be operated simultaneously and the connections are easily accessible on both sides of the drawbar.

### Dynamic steering.

Dynamic steering allows the driver to adjust the ratio between the steering wheel and front axle steering angle to suit their preferences. Using CEBIS or the CIS colour display, the driver can choose between two automatic programs and one manual mode, and also select the intensity of the steering ratio.

The two automatic programs adjust the steering ratio according to the forward speed or current steering lock. This means that the system can be individually adjusted to suit all requirements. In steering angle-dependent mode, the steering ratio is greatly reduced when travelling in a straight line. The more the driver steers, the faster the steering responds. This allows the driver to steer the tractor in a straight line with great precision but still manoeuvre quickly.

In speed-dependent mode, the steering ratio is proportionally reduced as the forward speed increases above 10 km/h. This is particularly useful during field work. As the tractor slows down at the headland, the driver can turn quickly with ease. As the tractor picks up speed, the steering ratio is reduced again to make it easier to drive straight ahead.

In manual mode, the ratio between steering wheel and steering angle is permanently linked to the four adjustable assistance levels.

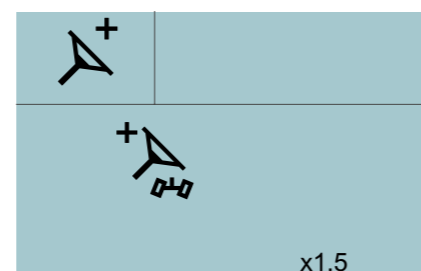

Setting dynamic steering in the CIS colour display

x1.5

### REVERSHIFT with park-lock function.

In addition to the familiar, easy-to-use clutchless reverser, the REVERSHIFT lever also has an integral park-lock function which provides a very easy way of keeping the AXION stationary. For even greater safety, the park-lock function is automatically activated in the following situations:

- When the engine is switched off
- When the engine is switched on
- If the accelerator or CMOTION has not been touched for a few seconds while the vehicle is stationary – regardless of the current REVERSHIFT lever position<sup>1</sup>
- As soon as the driver's seat is vacated when the vehicle is stationary<sup>1</sup>

<sup>1</sup> Only with CMATIC

### Automatic adjustment.

During braking, the front axle suspension automatically adjusts to the change in load. The tractor therefore retains its normal stability and safety even during sharp braking manoeuvres.





# Powerful and economical at the push of a button.

The right speed every time.

Three different PTO options are available for all AXION 800 models:

- 540 / 1000 rpm
- 540 / 540 ECO / 1000 rpm
- 540 ECO / 1000 / 1000 ECO rpm

It's easy to preselect the PTO speed at the touch of a button. Another button on the armrest activates the PTO.

Automatic PTO engagement / disengagement is activated at a specified linkage height which is continuously adjustable. To save the height, you just move the rear linkage to the required position and give a long press on the automatic PTO button.

The integral freewheel on the rear PTO makes implement hitching simple.

Standing start.

The 540 / 1000 rpm PTOs reach their full speed precisely in the maximum engine output range. As a result, even heavy PTO-driven implements are no problem for these tractors. In ECO PTO mode the engine runs at a low, fuel-efficient speed. During light work, the lower engine speed can reduce noise levels and save valuable fuel.

#### Rotational speeds:

- 1000 rpm ECO at 1,600 engine rpm
- 540 rpm ECO at 1,520 engine rpm



PTO with the right engine speed.

A press of a button on the rear mudguard is all it takes to switch on the rear PTO and then activate the engine speed memory. Just set the right engine speed for the attached implements in CEBIS in advance. This is recommended for all operations when you routinely use the external PTO switch. It saves time and makes your job easier and safer.



External controls for rear PTO on both mudguards



The PTO stub can be changed easily





# Powerful hydraulics. Simple connections.

## Pressure-free connections and no mess.

All ten hydraulic couplings at the rear of AXION 870-800 tractors have release levers, so they can be connected and disconnected even under pressure.

The colour-coding on the inlet and outlet sides make it easier to attach implements correctly. Oil leakage lines collect the oil from the couplings when attaching and removing connectors.

## Hydraulics that get the job done.

- Load-sensing hydraulic system for all AXION 800 models with 110, 150 or 205 l/min output
- With CIS: four mechanical spool valves operated from the right-hand side console and ELECTROPILOT controls for two electronic spool valves on the armrest
- With CIS+: up to six electronic spool valves can be operated from the armrest – up to four of these with the ELECTROPILOT
- With CEBIS: controls for up to seven electronic spool valves on the armrest – four of which can be operated by ELECTROPILOT. Thanks to free assignment and prioritisation of the spool valves, every driver can adapt CEBIS operation to suite their personal preferences and the task in hand. The frequently used hydraulic functions are positioned side by side for smooth operation.
- With CEBIS and CIS+: spool valve operation can be assigned to the F buttons on the CMOTION, multifunction armrest or ELECTROPILOT to lighten the workload during combined operating processes.



## Power Beyond.

Power Beyond connections are provided at the rear for implements which have their own control units.

In addition to the standard pressure, return and signal lines, the tractor also has a free-flow return line. The AXION is therefore prepared for operation of hydraulic motors with a separate return line, even when the Power Beyond connections are in use.

### The benefits of this are:

- Hydraulic oil is supplied to the attached implement as required
- Large-diameter lines and non-pressurised return flow reduce power losses



When a front linkage is installed, up to four hydraulic connections and one free-flow return line are available at the front. Ideal for a front-mounted seed hopper or dozer blade.

Equipment	CIS	CIS+	CEBIS
Max. number of mechanical spool valves, rear	4	–	–
Max. number of electronic spool valves, rear	–	4	5
Max. number of electronic spool valves, centre, e.g. for connections to the front or a front linkage; operated from ELECTROPILOT	2	2	2
Spool valve prioritisation	–	–	□
Free spool valve assignment	–	–	□

□ available – not available



Lifts any implement.  
The rear linkage.



External controls for the rear linkage, PTO and one freely selectable spool valve (CEBIS only)



Several positions are available in the drawbar versions. The extended position improves manoeuvrability.

### A hitch to suit every need.

The tow hitch support on the AXION is ISO 500-compliant. This means that hitches on other machines which conform to the same standard can be used. A wide range of factory-fitted hitch options are available:

- Pick-up hitch
- In the drawbar frame:
  - automatic clevis, 38 mm
  - K80 hitch ball and positive steering (up to 4.0 t drawbar load)
  - CUNA hitch system
- As a drawbar:
  - with Cat. 3
  - with K80 hitch ball and positive steering (4.0 t drawbar load)
- Tow hitch support with Piton-Fix coupling

### Direct adjustment.

The main rear linkage functions are directly accessed via push buttons and dials on the right-hand B-pillar:

- Manual lift and lower for machine attachment
- Vibration damping on / off
- Lock rear linkage
- Activate slip control
- Lift height limiter
- Lowering speed
- Draught and position control
- Adjustment of wheel slip control

The convex rear window and swivelling seat provide an excellent view of the implement and unimpeded operation of the rear linkage controls. The conveniently located controls enable the driver to optimise the rear linkage settings while work is in progress.

### The rear linkage.

With a maximum lift capacity of 10 t, these tractors can carry the heaviest of implements. The configuration of the rear hydraulic system can be tailored to individual requirements:

- Manual or automatic lower link stabilisers
- Wheel slip control via radar speed
- Hydraulic top link
- Practical ball holder at the rear
- Excellent view of linkage and drawbar
- Both mudguards are fitted with external controls for the rear linkage, PTO and one electronic spool valve (CEBIS only)





More versatility.  
More applications.



Front linkage.

All AXION 800 models can be factory-fitted with two different front linkages:

- 4.6 t max. lift capacity
- 5.8 t max. lift capacity

The modular construction makes retrofitting straightforward.

Front linkage and front PTO.

All models feature a front linkage and front PTO:

- Three positions for the front lower links: folded up, fixed working position and float position in slotted hole
- Short distance between front axle and mounting points for improved guidance of front attachments
- 1,000 rpm PTO
- External controls for the front linkage and one double-acting spool valve in the CEBIS or CIS+ version



Always connected.

Optional hydraulic and electronic interfaces for many applications are incorporated into the front linkage:

- Up to two double-acting spool valves
- Free-flow return line
- 7-pin socket
- ISOBUS socket



External controls for the front linkage and one spool valve in the CEBIS version

Precise work.

The optional front linkage position control system for the CEBIS version enables front-mounted implements to work extremely accurately. The working position is adjusted via a rotary knob on the armrest, while the lift height can be limited and the lifting and lowering speed can be set using CEBIS. The front linkage can be used in single- or double-acting mode.



Greater comfort  
means higher productivity.

Spacious and quiet, with large windows and full suspension: the cabs on AXION tractors guarantee maximum comfort throughout long working days.

**CEBIS.**

- CEBIS terminal operated via touchscreen or rotary switch
- Innovative CMOTION multifunction control lever with draught-free internal ventilation
- ISOBUS-UT user interface built into CEBIS





# Ticking all your boxes. The cab.

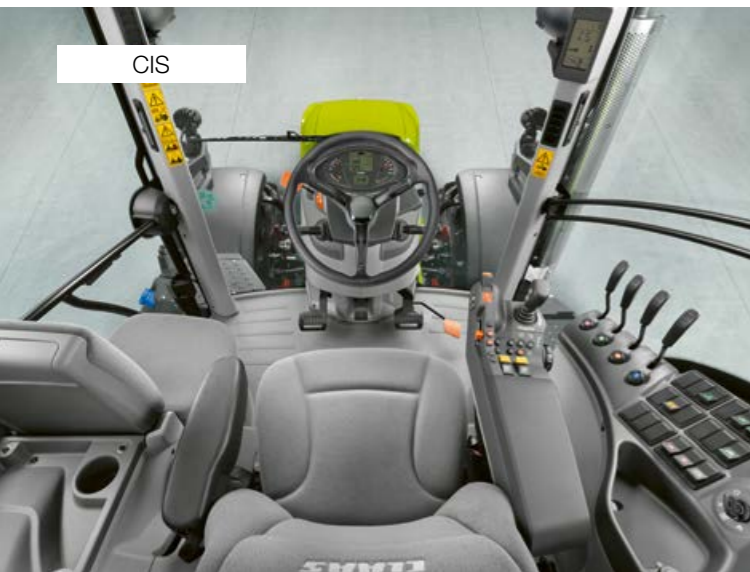

CIS

## CIS. Simply good.

In the basic version, the AXION has mechanical spool valves and the CLAAS INFORMATION SYSTEM (CIS). The CIS display features a compact design and outstanding control ergonomics: all settings are easily activated using a rotary switch and the ESC button. Two electronic spool valves for connections to the front or the front linkage are also available as an option in the CIS version and are operated via the ELECTROPILOT on the armrest.

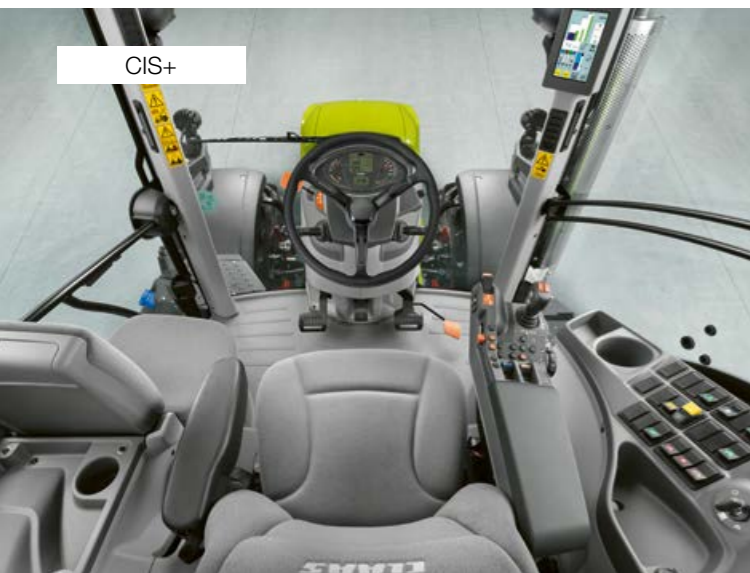

CIS+

## CIS+. Simply more.

CIS+ affords impressive ease of use and an intuitive design. Despite its pleasing simplicity, it has all the necessary functionality and the automatic functions needed for effective, effortless operation. CIS+ is also available with a continuously variable CMATIC or HEXASHIFT powershift transmission. The 7" CIS colour display built into the A-pillar combines display and setting options for the transmission, electronic spool valves, F buttons and CSM headland management.

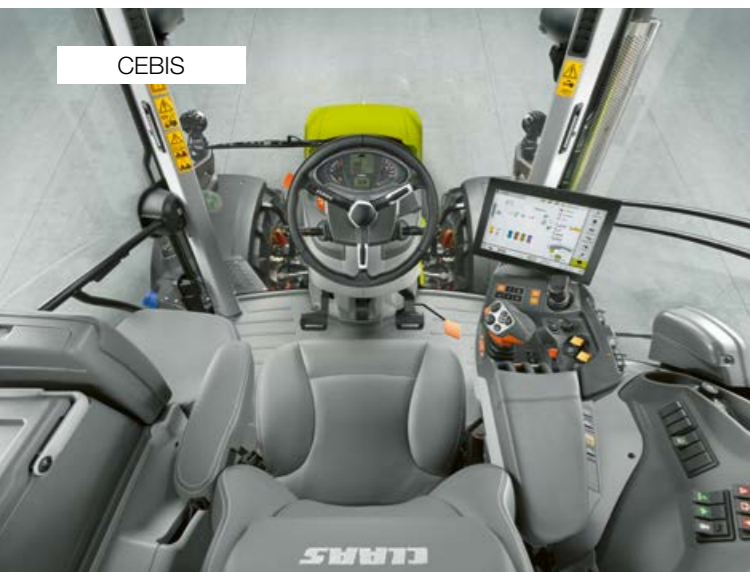

CEBIS

## CEBIS. Simply everything.

With the CMATIC or HEXASHIFT transmission, the CEBIS version features electronic spool valves and the superb CEBIS terminal with a 12" touch display. As well as enhanced automatic functions such as CSM headland management, camera image, ISOBUS implement control, CEMOS for tractors and spool valve prioritisation, it also offers many other functions – CEBIS meets your every need. All settings can be entered in seconds thanks to touchscreen operation and logical menu navigation.

## 4-pillar concept.

The CLAAS 4-pillar cab offers some distinct advantages:

- Clear view of the full working width of attached implements
- Large-volume cab creates an extremely spacious working environment
- Continuous windscreen

The layout and positioning of the controls are inspired by the design of the CLAAS AXION 900 and ARION 600 / 500 series. The controls and menu structure of the CIS, CIS+ and CEBIS versions are the same in all models. The CMOTION multifunction control lever has also become an established feature of CLAAS harvesters. CLAAS places great emphasis on having a standardised control structure so that every driver immediately feels at home in the cab and knows how to operate the controls right from the start.

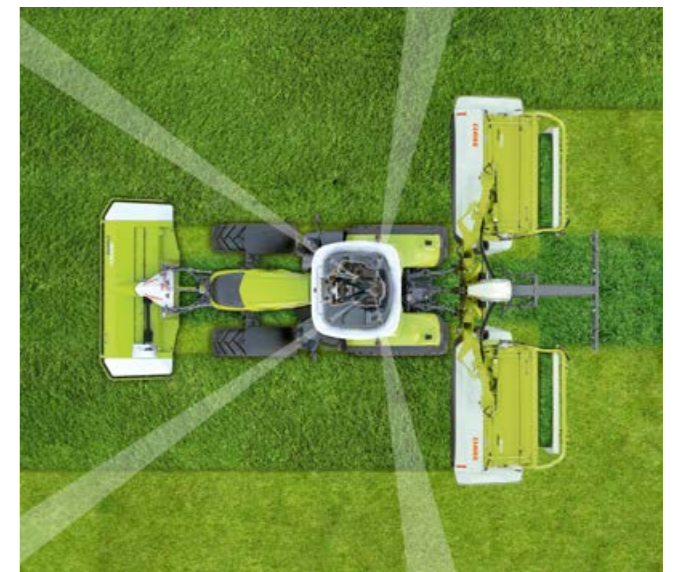

The cleverly positioned rear cab pillars and convex rear window give the driver an excellent view of the implement and hitch area

AXION equipment	CIS	CIS+	CEBIS
CIS display in the A-pillar, DRIVESTICK and multifunction armrest	●	–	–
CIS colour display in the A-pillar, DRIVESTICK and multifunction armrest	□	●	–
CEBIS touchscreen terminal, CMOTION multifunction control lever and multifunction armrest	–	–	●
CMATIC continuously variable transmission	–	□	□
HEXASHIFT powershift transmission	●	□	□
PTO shaft management	●	●	●
Max. number of mechanical spool valves	4	–	–
Max. number of electronic spool valves	2	6	7
Max. number of electronic spool valves operated by ELECTROPILOT	2	4	4
CSM headland management	–	□	–
CSM headland management with edit function	–	–	●
Implement management	–	–	●
Tractor task management	–	–	●
Camera image	–	–	□
ISOBUS implement control	–	–	□
CEMOS for tractors	–	–	□
TELEMATICS and other online functions	□	□	□

● standard □ optional □ available – not available



# CEBIS version. Simply everything.

## An armrest that sets new standards.

All the main controls are integrated into the right-hand armrest:

- 1 CMOTION multifunction control lever
- 2 Control panel for drive mode, range changing and two engine speed memories with fine adjustment
- 3 CEBIS terminal with 12" touchscreen
- 4 ELECTROPILOT with two double-acting spool valves and two F buttons
- 5 CEBIS control panel
- 6 Working depth adjustment for front and rear linkage
- 7 Activate front and rear PTO
- 8 Hand throttle
- 9 Transmission in neutral, activate front linkage
- 10 Electronic spool valves
- 11 Four-wheel drive, differential lock, automatic PTO engagement / disengagement, front axle suspension
- 12 Main switch: battery, electronic spool valves, CSM, steering system



The height and position of the armrest can easily be adjusted to the driver's requirements.

Functions that are used less frequently, such as PTO speed preselection and the main switches, are located to the right of the driver's seat.

When the driver's seat is rotated, the electronic linkage control system can be operated comfortably with an excellent view of the attached implement. This allows settings to be finely adjusted while work is in progress. Two additional buttons enable the rear linkage to be raised and lowered manually for easier implement attachment.

## Uncluttered layout.

In all versions, several functions can be controlled directly using the rotary switches and buttons on the B-pillar:

- 13 PTO speed selection
- 14 Rear linkage settings
- 15 Rear linkage status display
- 16 Controls for electronic rear linkage control system



# CMOTION multifunction control lever. Everything in hand.



## CMOTION multifunction control lever.

The CMOTION is a CLAAS concept which makes using the main functions of the AXION easier and more efficient. Functions are controlled using your thumb and forefingers, allowing your arm to rest comfortably on the padded armrest and preventing fatigue.

## Operating the HEXASHIFT or CMATIC.

All HEXASHIFT shifting operations are carried out using the CMOTION. A slight push activates the powershift speeds.



Progressive operation with CMATIC continuously variable transmission technology

By pushing the CMOTION further forwards or backwards, it is possible to select ranges directly and skip powershift speeds. With the CMATIC, the forward speed can be adjusted precisely and continuously using the CMOTION.

## At the push of a button.

The eight function buttons on the CMOTION can be freely assigned, so there is no need to reposition your hands while you work. All implement-specific ISOBUS functions are easily controlled using the CMOTION:

- ISOBUS functions
- Event counter on / off
- Spool valves

## Rear linkage functions on the CMOTION:

- Lower to preset working position
- Raise to preset lift height position
- Manual activation: lift and lower at two speeds (slow / fast)
- Quick implement entry

- 1 Start up / change direction
- 2 Rear linkage
- 3 Activate GPS PILOT
- 4 CSM headland management
- 5 F7 / F8 / F9 / F10 function buttons
- 6 Activate cruise control
- 7 F1 / F2 function buttons
- 8 F5 / F6 function buttons



# CEBIS terminal. Everything under control.



## Clear layout and fast operation.

The 12" CEBIS screen uses self-explanatory symbols and colour coding to give a clear picture of the settings and operating statuses. Thanks to the CEBIS menu structure and touchscreen, all settings can be entered in just a few steps. A particularly attractive feature is the DIRECT ACCESS function with the machine silhouette. Just tap the relevant area to get straight to the right dialogue window.

## An eye-catching 12" screen.

- 1 Machine silhouette for DIRECT ACCESS and status display
- 2 Spool valve status
- 3 Vehicle information
- 4 Top sub-field: performance monitor
- 5 Middle sub-field: function button assignment
- 6 Bottom sub-field: transmission information
- 7 Menu
- 8 DIRECT ACCESS via CEBIS touch button or button on the armrest

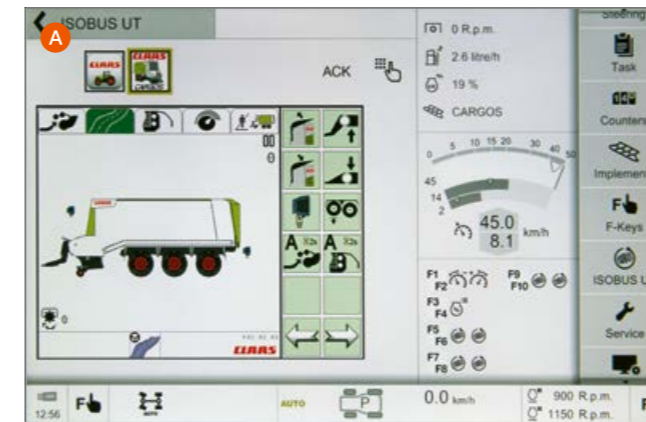

### Integrated ISOBUS implement control (A).

- In CEBIS intuitively switch between ISOBUS implements, road travel and field work screen layouts
- Clear view of ISOBUS implements in main field
- Simply connect ISOBUS cable at the front or rear and off you go
- Assign up to ten ISOBUS functions to CMOTION function buttons for direct operation

### Camera image display function (B).

- 1 Display up to two camera images in the sub-field
- 2 Toggle between machine silhouette, Camera 1 and Camera 2 in the main field

## CEBIS – simply better:

- Fast and intuitive navigation using the CEBIS touchscreen
- Rapid access to the sub-menus with the DIRECT ACCESS touch button on CEBIS or button on the armrest
- Tap the machine silhouette, main field or sub-field
- Navigate using the rotary switch and ESC button on the armrest – ideal when driving on rough terrain
- Two different screen layouts available (road travel and field work)
- ISOBUS function
- Specify the user type: limit the scope of CEBIS settings to suit driver experience
- Freely assign the three sub-fields, e.g. for transmission, front and rear linkage, function buttons, headland sequences, camera or performance monitor

As well as screen-based operation with CEBIS, there is a set of buttons in the armrest. Full CEBIS operation is available using the rotary switch and ESC button if uneven ground reduces the accuracy of fingertip operation. The DIRECT ACCESS button takes you straight to the settings for the last used tractor function.



- 1 Menu navigation
- 2 Select
- 3 ESC button
- 4 DIRECT ACCESS button





### Everything to hand.

The height and position of the armrest can easily be adjusted to the driver's requirements.



- 1 DRIVESTICK to operate the CMATIC or HEXASHIFT transmission
- 2 Controls for rear linkage and two F buttons, e.g. to activate CSM headland management
- 3 Hand throttle, two engine speed memories, GPS PILOT, four-wheel drive and differential lock
- 4 ELECTROPILOT four-way control lever with two F buttons and buttons to change direction
- 5 Control panel for transmission and hydraulic function activation
- 6 Electronic spool valves
- 7 Set working depth of rear linkage
- 8 Activate front and rear PTO plus automatic engagement / disengagement of rear PTO
- 9 Activate front axle suspension



### The ergonomically perfect armrest.

The multifunction armrest has been designed for optimum ergonomics and is the key to relaxed and effective working. It's the result of extensive analyses of the operating processes in the cab: frequently required functions are located on the multifunction armrest, while those required less frequently are located on the right-hand side console.

### An instinct for excellence – CMATIC operation.

The unique DRIVESTICK with handrest at the side handles intuitively and gives full control of the HEXASHIFT or CMATIC transmission.

Unlike conventional drive levers, the DRIVESTICK comes with proportional control of a CMATIC transmission. This means that the further it is pushed or pulled when in drivestick mode, the faster the transmission accelerates or brakes the tractor.

This functionality is not needed so often in accelerator pedal mode as the driver controls the speed with the foot pedal. However, it is still very useful, for example to manually increase or reduce the engine braking effect.

When the DRIVESTICK is used in conjunction with the CMATIC transmission, it also has a cruise control button. Just press the button briefly to activate cruise control, or press and hold to save the current speed. If cruise control is active, the speed can be changed simply by moving the DRIVESTICK forwards or backwards.

CIS+. Simply more.

### CEBIS does it, so does CIS+.

- Set or activate individual flow and time control for individual spool valves
- Continuously variable PTO engagement / disengagement settings based on rear linkage height
- Record and run four CSM headland management sequences
- Operate ISOBUS implements using the F buttons on the tractor



The PTO speed and electronic rear linkage control system can be adjusted on the B-pillar



CIS version.  
Simply good.



Everything to hand.

The height and position of the armrest can easily be adjusted to the driver's requirements. All frequently used functions are located on the armrest.

- 1 DRIVESTICK to operate the HEXASHIFT transmission
- 2 Controls for rear linkage and two F buttons
- 3 GPS PILOT and two engine speed memories
- 4 Hand throttle
- 5 Fine tuning of engine speed memory
- 6 Control panel for transmission, HEXACTIV auto-shift function
- 7 ELECTROPILOT
- 8 Set working depth of rear linkage
- 9 Activate front and rear PTO
- 10 Mechanical spool valves



An instinct for excellence –  
HEXASHIFT operation.

The unique DRIVESTICK handles intuitively and gives full control of the HEXASHIFT transmission. Complex and cumbersome shifting operations are a thing of the past. All you need is nimble fingers to shift as you please.

The ergonomically perfect armrest.

The multifunction armrest has been designed for optimum ergonomics and is the key to relaxed and effective working. It's the result of extensive analyses of the operating processes in the cab: frequently required functions are located on the multifunction armrest, while those required less frequently are located on the right-hand side console.



Settings made simple.

Each spool valve has its own rotary switch. The function options for each spool valve are selected using the rotary switch allocated to it:

- Rotary switch in position III: Pressure – / Neutral / Pressure + / Float position
- Rotary switch in position III: Pressure – / Neutral / Pressure +
- Rotary switch in lock position: Spool valve locked in pressure position for permanent operation or in neutral position



The PTO speed and electronic rear linkage control system can be adjusted on the B-pillar



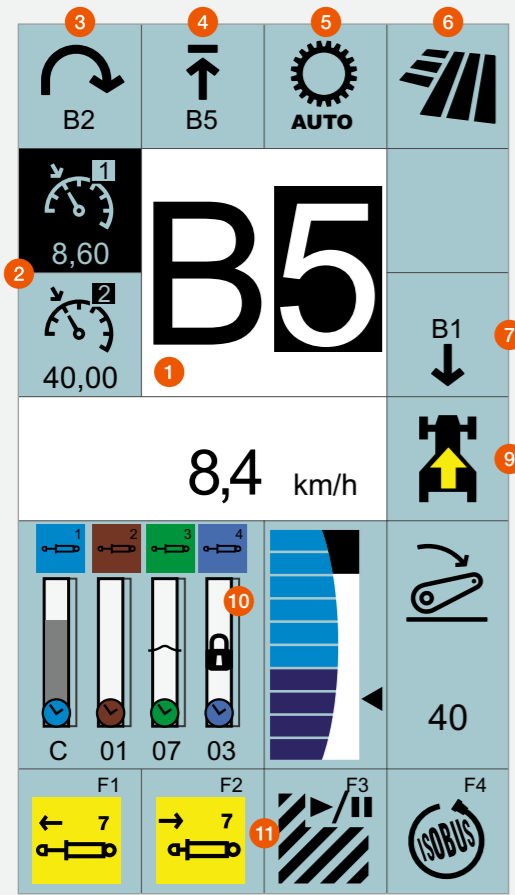

CIS colour display on the A-pillar with HEXASHIFT transmission

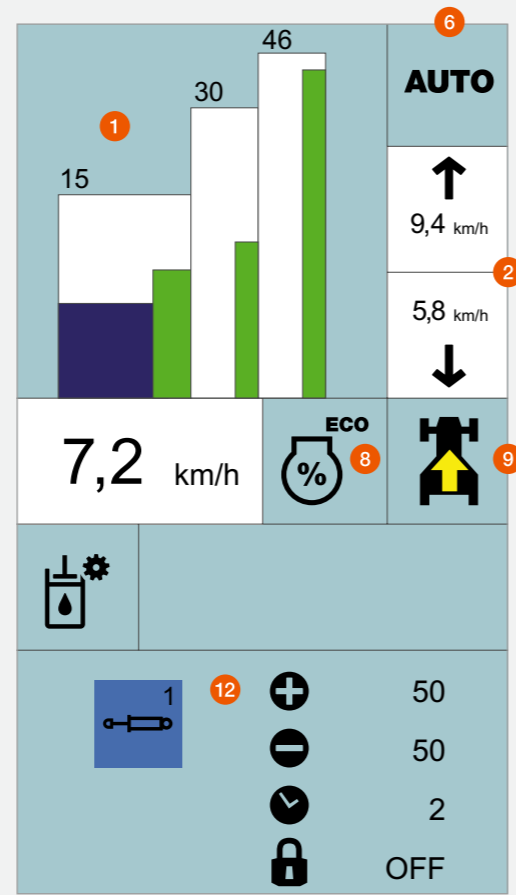

CIS colour display with CMATIC transmission and settings menu

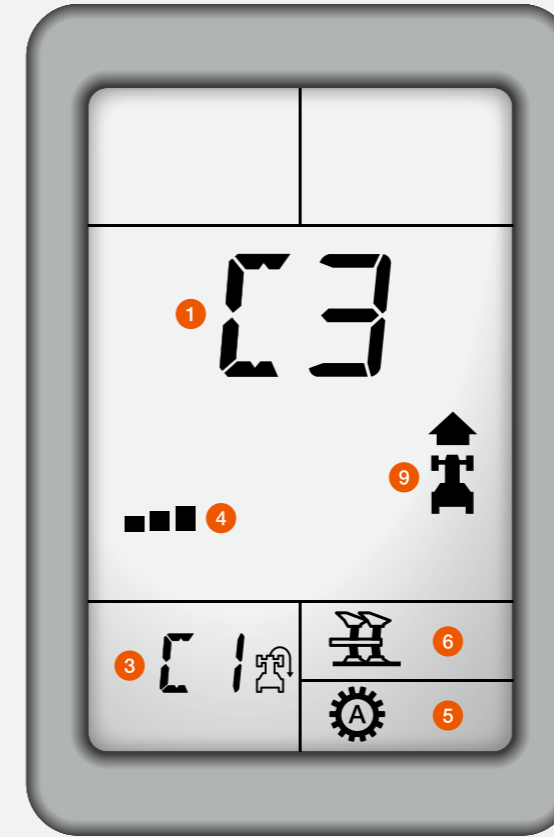

CIS display on the instrument panel and HEXASHIFT transmission display on the A-pillar

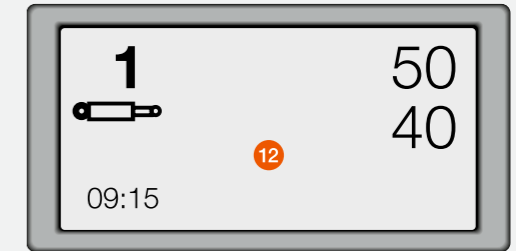

- 1 Current gear / CMATIC range
- 2 Cruise control and engine speed memory values
- 3 Selected headland gear
- 4 HEXACTIV auto-shift limiter
- 5 HEXACTIV mode
- 6 Current driving mode
- 7 Reverse gear
- 8 Selected engine droop
- 9 Direction of travel or transmission in neutral
- 10 Status of rear linkage and spool valves
- 11 Function button assignment
- 12 Settings menu

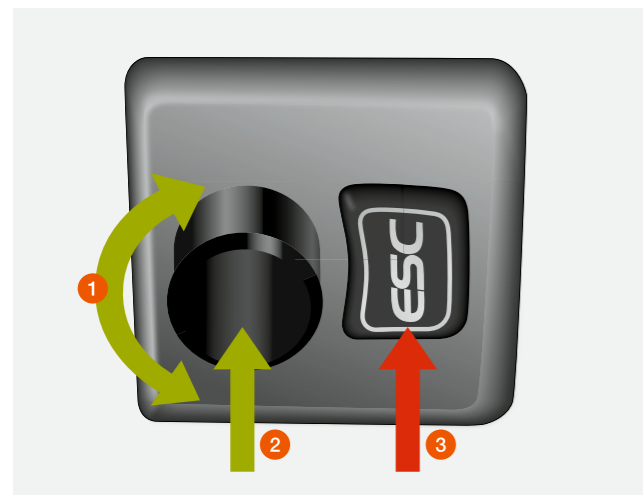

- 1 Menu navigation
- 2 Select
- 3 ESC button

### The CLAAS INFORMATION SYSTEM (CIS).

In the CIS version, the display is built into the instrument panel. The additional HEXASHIFT display on the A-pillar shows all the information relating to the transmission at a glance.

#### CIS+:

The modern design of the 7" colour CIS display on the A-pillar provides the driver with full information about the transmission, electronic spool valves and F buttons. This colour CIS display shows the settings in the lower part of the screen. The logical, menu-guided interface and clear symbols make navigation very simple.

In both versions, all settings are easily activated using a rotary switch and the ESC button on the steering wheel.

The following functions can be set using the CIS:

- CMATIC or HEXASHIFT transmission settings
- Additional functions e.g. SMART STOP or dynamic steering
- Progressivity of the REVERSHIFT clutchless reverser
- Time and volume settings for the electronic spool valves
- On-board computer functions such as area worked, fuel consumption, area output
- Maintenance interval display



# Ergonomics and comfort for optimum working conditions.



## First-class comfort.

The AXION has several practical features which make it the ideal choice for long working days. A large number of storage options means that the driver can always find space for a mobile phone or documents. Under the passenger seat there is a cooler compartment which has room for two 1.5 litre bottles and snacks. Perfect for your lunch break.

## LED headlights for perfect illumination.

If you're still working when it goes dark, the work lights will light up the whole of the area around the machine, so you can see exactly what you're doing. For even more demanding situations, up to 20 LED work lights and four LED road lights can illuminate the entire surroundings of the AXION almost as brightly as daylight.

## A pleasant place to work.

All AXION models are fitted as standard with air conditioning and, optionally, with a category 3 filter. All components are built into the double-insulated cab floor to ensure quiet operation.



As well as the manually controlled air-conditioning system, a fully automated version is available which provides a pleasant flow of air through the cab



## Clear and logical layout.

The instrument panel is mounted on a fully adjustable steering column. It pivots with the column to give an unimpeded view of the controls at all times.



## Illuminated interior.

When the road lights are switched on, all the controls and the symbols on all the switches are illuminated. You have the option to select a darker colour scheme in CEBIS.



## Leather on request.

The driver and passenger seat are available with modern, non-slip fabric or elegant, easy-care leather upholstery.



## Sockets in easy reach.

All the sockets for the power supply as well as ISOBUS sockets for additional terminals are located under the right console.



## Bluetooth mobile phone connection.

With the built-in Bluetooth hands-free device with external microphone, you can make clear calls from the comfort of your cab.



## More fresh air.

Choose between a front-opening transparent sunroof or a rear-opening roof hatch.



## Wide-angle for better visibility.

As well as the large standard mirror, a wide-angle mirror for improved road safety is supplied as standard.



## Non-slip leather steering wheel.

The robust leather steering wheel provides a secure grip and an uninterrupted view of the instrument panel whatever position it's in.



## Tinted rear window.

The tinted rear window (optional) helps maintain a comfortable cab environment and reduces glare when you're working in the low evening sun.



# Protects both driver and machine. The suspension.



## Full suspension.

Four suspension points mean that the cab is fully isolated from the chassis, preventing impacts and vibration from reaching the driver. Longitudinal and lateral struts join the suspension points and keep the cab stable when turning corners or braking. The entire suspension system is completely maintenance-free.



## Ventilated and warm: the premium seat.

The range of Sears and Grammer seats includes a ventilated premium seat.

- Active seat ventilation and heating make the seat feel comfortable whatever the weather
- Semi-active suspension adjusts automatically to the weight of the driver
- Longitudinal and lateral horizontal suspension



## PROACTIV front axle suspension – complete comfort automatically.

The suspension adjusts to tractor loading and automatically remains in the central position. Changes in load due to braking and turning manoeuvres are also compensated for. Parallelogram axle suspension and 85 mm spring travel guarantee a smooth ride.



## Vibration damping.

Heavy implements mounted on the front put a strain on the tractor as well as the driver. The front and rear linkage are both equipped with vibration damping to compensate for peak loads during transport operations and when the attached implement is raised at the headland.



Activate front axle suspension



## Operator assistance systems.

There is no substitute for your experience. It's what allows you to respond quickly and appropriately to the challenges you face in your daily work. When you're dealing with difficult terrain or changing soil conditions, you have to make decisions very quickly to get the job done to the right standard. That's why it's good to be able to count on a tractor with CEMOS to reduce your workload.

## Data management.

Data has long since become an indispensable resource. To profit from its full potential, you should take just as good care of your data as you do your machinery fleet. And that includes making sure all systems, machines and processes are meaningfully connected and the data generated is sent to the appropriate place for analysis.

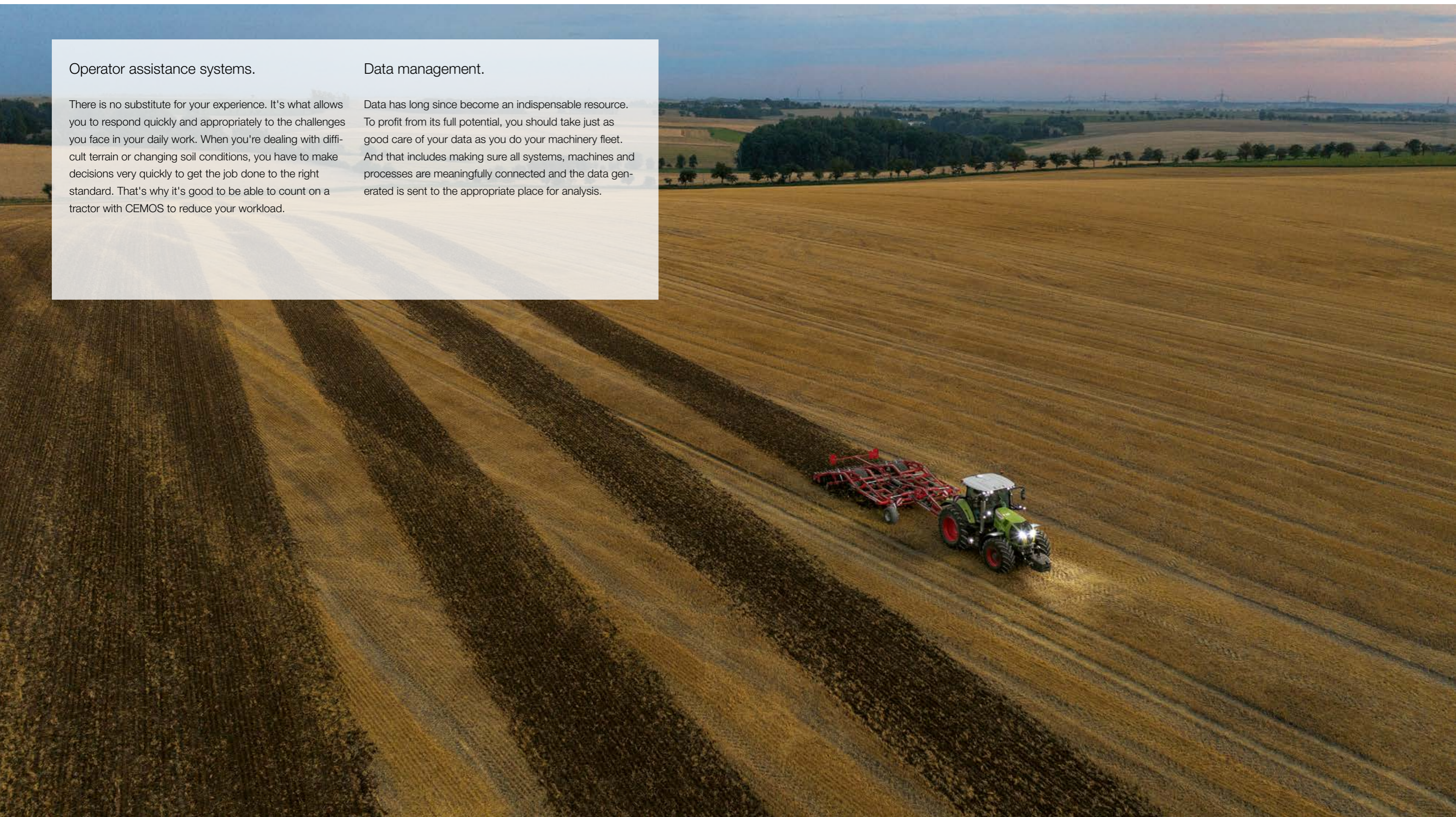





More information about new CEMOS features and the CEMOS DLG test. [ceмос.claas.com](http://ceмос.claas.com)

Scan me.

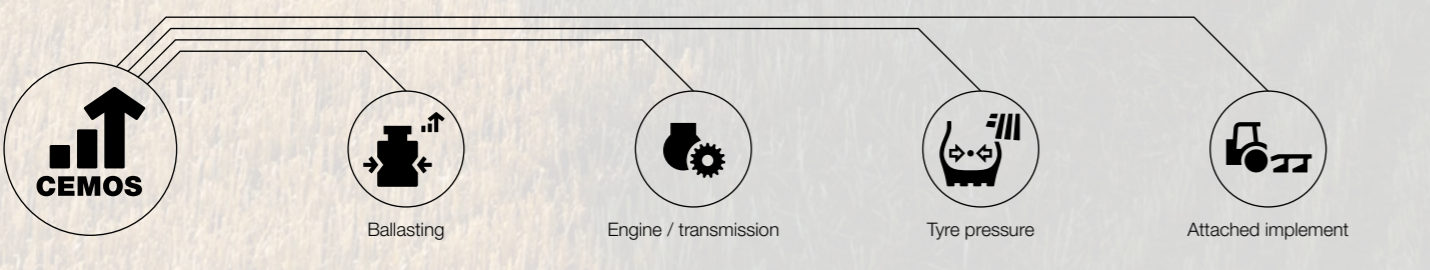

### Phase 1. Preparation in the farmyard.

CEMOS recommends the required ballasting and optimum tyre pressure to suit the selected implement and task before the driver has left the farmyard. The dynamic learning system gathers more measurements while work is under way, and adapts its recommendations accordingly next time around.



### Phase 2. Basic setting in the field.

The integrated CEMOS knowledge database provides step-by-step instructions on basic settings for implements, with illustrations. Assist systems are now available for all ploughs. Further implements will follow in the near future. These provide valuable assistance for drivers working with new or unfamiliar implements.

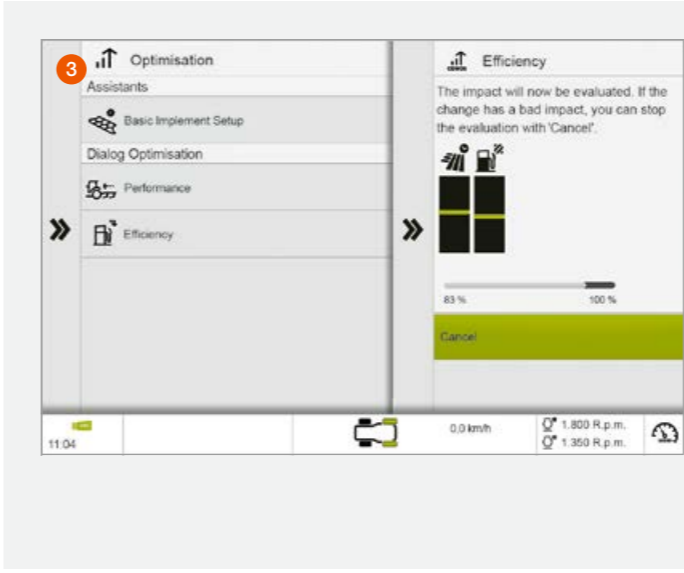

### Phase 3. Optimisation while work is under way.

The driver opens the optimisation dialogue in the field. CEMOS checks all the basic settings, and offers suggestions for improving "performance" and "efficiency", which the driver can accept or reject. After each change of setting, CEMOS recalculates and shows whether the work rate and diesel consumption have improved, and by how much.



### CEMOS teaches itself and trains the user.

The CEMOS self-learning operator assistance system is the only one of its kind on the market to optimise the performance of both the tractor and attached implements such as ploughs and cultivators. So it helps the driver set the correct ballast and tyre pressure. CEMOS uses a dialogue-based interface to make recommendations for all important settings, e.g. for the engine, transmission and implement. This helps to ensure optimum traction and soil protection at all times. With CEMOS you can increase your work rate, improve the quality of your work and reduce your fuel consumption by 16.8%.



# Precision at the headland with CSM.



## CLAAS SEQUENCE MANAGEMENT.

CSM headland management takes the load off you whenever you need to manoeuvre at the headland. You can run any of the previously recorded functions simply by pressing a button.

	With CIS+	With CEBIS
Number of storable sequences	Four	Four per implement, up to 20 implements
Sequence activation	F buttons	CMOTION and F buttons
Sequence display	On CIS display	On CEBIS display
Recording mode	Time-related	Time- or distance-related
Edit function	–	Subsequent sequence optimisation in CEBIS

The following functions can be combined in any order:

- Spool valves with time and flow control
- Four-wheel drive, differential lock and front axle suspension
- Front and rear linkage
- Cruise control
- Front and rear PTO
- Engine speed memory

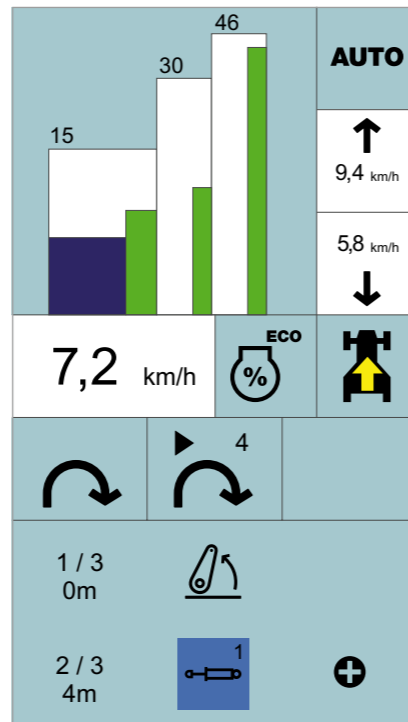

The sequence flow is shown in the lower area of the CIS colour display

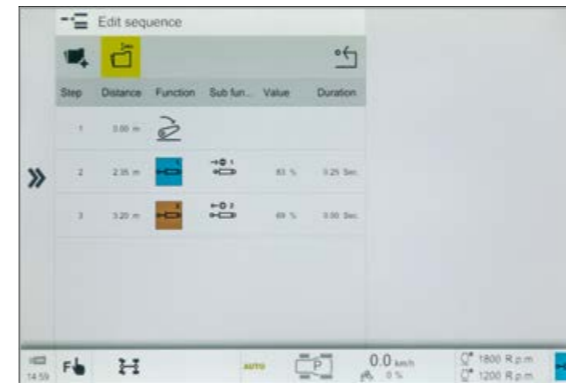

Easy to record and run.

Sequences can be recorded on a distance- or time-related basis. In recording mode, clear symbols guide the driver step-by-step through the process of creating the sequence on the CEBIS or CIS colour display. A sequence that is running can be paused and restarted simply by pressing a button.

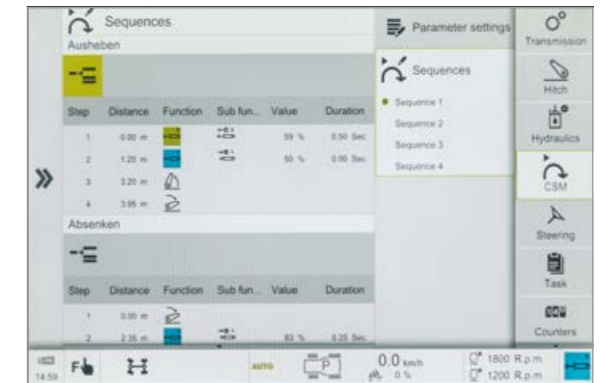

Non-stop optimisation with CEBIS.

Recorded sequences can be changed and optimised in CEBIS at a later date. Steps can be added and deleted or changed and adapted in minute detail, allowing times, distances and flow volumes to be tailored to current conditions. Once a sequence has been recorded, it can be refined down to the last detail in just a few steps.



# GPS PILOT CEMIS 1200.

## Precision farming made easy.

Precise, future-proof, simple.

Improve the profitability of your farm and simplify day-to-day operations – step into the future with the CEMIS 1200 terminal.

With the GPS PILOT automatic steering system, your harvesting machine will seem like it's running on rails: always on the right track, using the full working width with no overlapping. There's no need for a long induction course. You'll be surprised how easy it is to operate an automatic steering system using the intuitive CLAAS user interface.

Thanks to ISOBUS and standard data exchange formats, the CEMIS 1200 is the way forward for more precision in farming.

### CEMIS 1200 terminal.

The CEMIS 1200 fits seamlessly into the cab: with the same intuitive control logic as CEBIS, operators will quickly find their way around.

You can use the system on all CLAAS machines set up for GPS PILOT CEMIS 1200. The terminal and receiver can be transferred from one machine to another in next to no time, giving you complete flexibility and saving money into the bargain.

### Benefits:

- Intuitive user interface for outstanding ease of use day and night
- Quick access to all important functions
- Freely configurable working areas for custom control

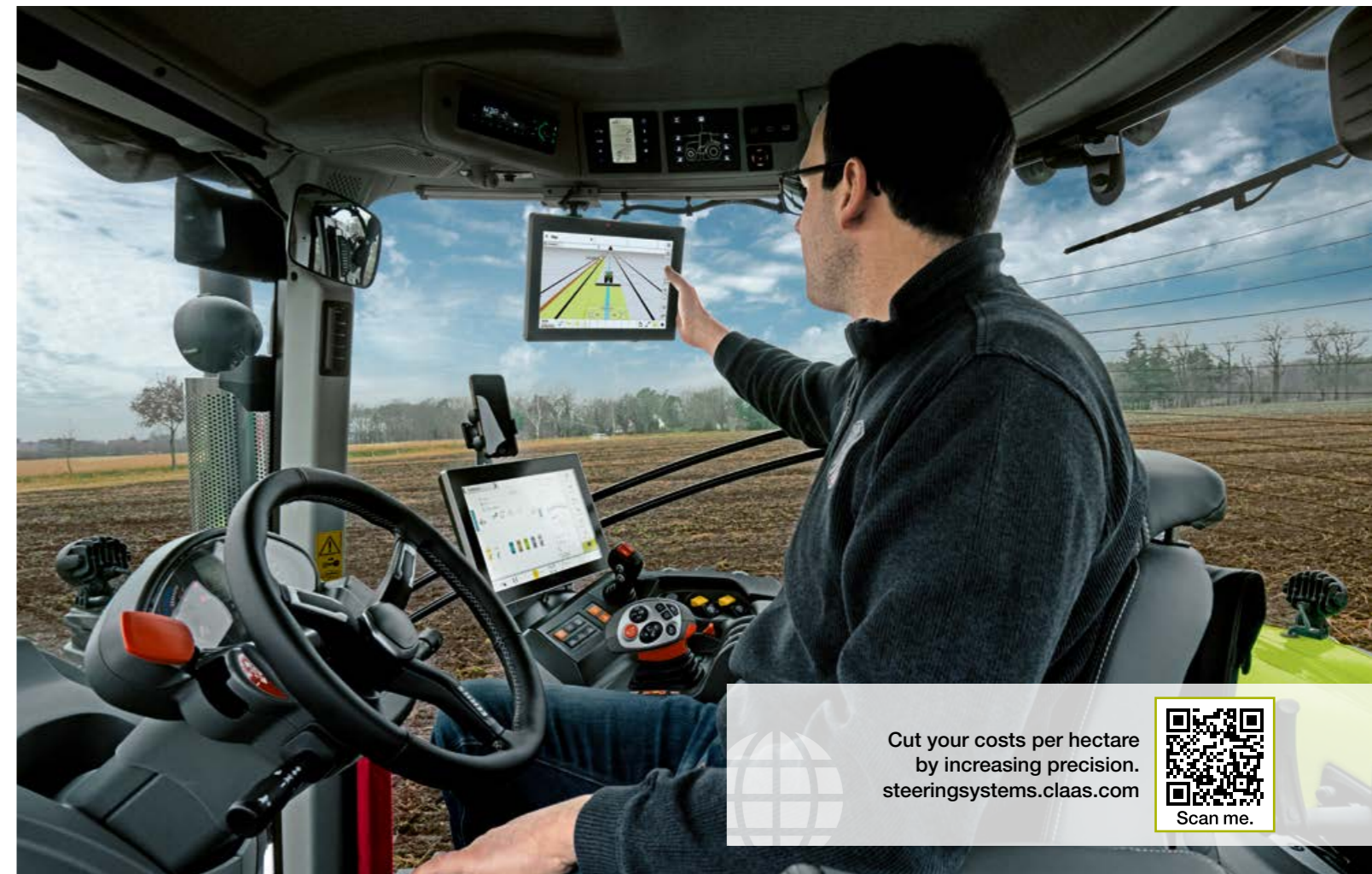

Cut your costs per hectare  
by increasing precision.  
[steeringsystems.claas.com](http://steeringsystems.claas.com)



Scan me.

### Precision guidance.

You need a good correction signal for precise work. It's a given with SATCOR 15<sup>1</sup> as standard for 5 years.

### Need even greater accuracy?

Choose the optional SATCOR 3<sup>1</sup> and SATCOR 3 FAST<sup>1</sup> correction signals ( $\pm 3$  cm).

### Absolute precision your top priority?

Choose the GPS PILOT CEMIS 1200 with RTK correction signal for the highest possible repeatable accuracy ( $\pm 2-3$  cm).

### RTK Bridging.

All RTK correction signals are enhanced by the RTK Bridging function as standard, so if the signal is lost, work can continue for up to 20 minutes with gradually decreasing accuracy.

### Difficult topography or mobile phone dead zones in your area?

With RTK Bridging Premium you can carry on working – without loss of accuracy or time limits.

<sup>1</sup> SATCOR 15 / SATCOR 3 / SATCOR 3 FAST powered by Trimble RTX. SATCOR correction signals, RTK Bridging and RTK Bridging Premium are not available in all regions. Together with your CLAAS distributor, we will find the best solution for your individual requirements.



# GPS PILOT CEMIS 1200. Moving with the times.

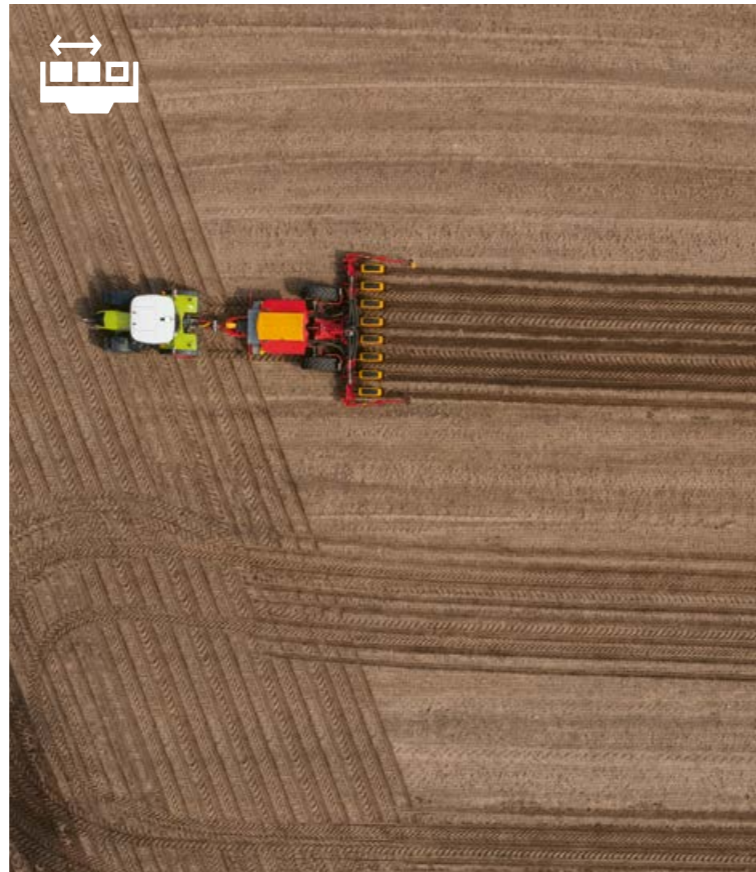
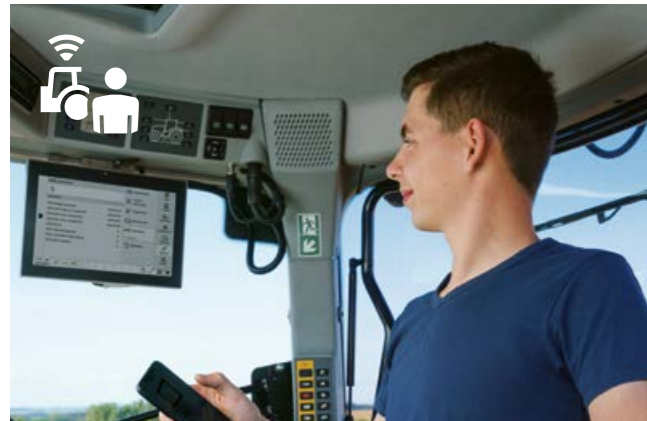

 **Future-proof – GPS PILOT CEMIS 1200.**

With GPS PILOT CEMIS 1200, you get a terminal fit for the future. Tailor-made for your farm, with full functionality pre-installed or added gradually to suit your growing needs.

Still not sure? Why not test additional functions and correction signals free of charge in advance?

Perhaps your requirements have changed during the season? No problem – with the digital connection you can adapt the system's functions quickly and flexibly to suit your needs. The appropriate licence or activation can be transferred online straight to your terminal.<sup>1</sup>

 **ISOBUS Universal Terminal (ISO UT).**

The ISO UT implement view can be displayed in the main work screen or in the smaller implement screen. This enables you to customise the display settings to suit your needs. The AUX-N allows functions to be assigned to physical function keys, for example on the CLAAS multifunction control lever.

**Benefits:**

- Customisable display settings for ISOBUS implements in the CEMIS 1200 terminal
- User-friendly operation using function keys
- Transfer new licences online or activate directly on the terminal

 **ISOBUS TC Section Control.**

The ISOBUS functionality of the CEMIS 1200 allows you to switch sections on or off automatically – for all the precision and none of the hassle.

 **Precision farming and documentation with ISOBUS TC-GEO and VRA.**

With ISOBUS TC-GEO you can easily record geo-referenced data such as application rates. If you want to target applications to specific areas, simply add the VRA (Variable Rate Application) module.

 **Office and machine seamlessly connected. Task management.**

With the CEMIS 1200 you can handle your job management via your mobile phone connection in just a few clicks – it's standardised and convenient.

Plan your tasks in your farm management software and transfer them straight from 365FarmNet or other connected systems to the machine via TELEMATICS. The operator has all the tasks in sight and can quickly and easily send them back to the office on completion.

Assign, complete and document – seamlessly and reliably.

<sup>1</sup> in countries with CLAAS connect



# A connected tractor is more productive.

## Digitalisation pays.

Digitalisation is a key factor in increasing your productivity and efficiency. Data generated in completely different places can be collected and evaluated centrally. This conserves your resources and improves your business processes.

To enable you to get more out of the AXION and your other machines, CLAAS offers a range of modules which allow systems, technology and working processes to be connected with each other, regardless of the manufacturer. Intelligent digitalisation matched to the requirements of your farm can reduce your workload significantly.

- Transfer and document machine and job data quickly
- Manage individual machines and the whole fleet efficiently
- Analyse working processes carefully and optimise them
- Analyse fields easily and map yields precisely
- Call up and manage farm data with intelligent farm management software
- Transmit data from different manufacturers' machines to TELEMATICS smoothly
- Save valuable maintenance and service time with remote diagnostics

## TELEMATICS records your success.

With TELEMATICS you can continuously retrieve and record work and performance data for your tractor. All data are transmitted via the mobile phone network from the machine to the server, where they are processed and stored. You can access and evaluate your data online in real time or retrospectively via the web portal or the TELEMATICS app. The Connected Documentation licence amalgamates all the data on a field-specific basis in the background. It is also possible to export your data to any current farm management software program.

## CLAAS API connects your office to your fleet.

With the DataConnect function, CLAAS, 365FarmNet, John Deere, Case, Steyr and New Holland have created a direct, multi-manufacturer, industry-wide and open cloud-to-cloud solution. This allows you to control and monitor your entire machinery fleet in the CLAAS TELEMATICS portal – safe in the knowledge that all relevant data are exchanged securely, conveniently and fully automatically. Both systems are components of CLAAS TELEMATICS.

## Remote Service costs you nothing.

Remote Service from CLAAS is an important machine networking element. It simplifies maintenance and service support significantly. The machine informs the service partner of an upcoming requirement for maintenance or sends immediate notification if a fault arises. The service partner has access to the relevant data and can prepare optimally for the intervention in both scenarios. CLAAS covers the cost of Remote Service for you during the first five years. All you have to do is give your consent.

## NEW: CEMIS 1200 manages your jobs.

With CEMIS 1200 and an active Connected Documentation licence, you can do your task management online with just a few clicks. Plan your tasks in your farm management software and transfer them to the machine via TELEMATICS. The operator has all the tasks in sight and can quickly and easily send them back to the office on completion.



## Digitalisation puts your farm ahead.

- TELEMATICS transfers your data from your machine straight to the cloud
- DataConnect allows you to process data from your machines, regardless of manufacturer
- With CEMIS 1200 you can create and manage all jobs on the spot in the machine.
- Remote Service simplifies maintenance and service support





Good access saves time and money.

Daily maintenance work should be as straightforward as possible – because we know from experience that nobody enjoys doing things that are complicated or inconvenient.

- The large, one-piece bonnet opens at the press of a button, providing access to all the engine maintenance points
- The engine oil can be checked and topped up on the left-hand side of the tractor when the bonnet is closed
- All daily maintenance tasks can be carried out without tools
- The front axle lubrication points are located in front of the radiator assembly for optimum accessibility
- The fuel prefilter is conveniently located by the left-hand cab access ladder
- Large drawer in the left-hand access ladder with space for a standard toolbox

The long oil-change intervals (engine 600 h, transmission and hydraulics 1,200 h) save time and money. As a result, less valuable working time is lost during the season and the tractor is where it should be – at work.

Fresh air for full power.

The large intake panels in the bonnet provide plenty of fresh air for cooling and for the engine air filter. Low flow rates at the intake panels keep them clean and permeable at all times.

The radiator assemblies are supported by a robust frame and have gas-filled shock absorbers that open the radiator panels to two positions for thorough cleaning. So cleaning can be carried out safely and conveniently as and when it is needed.

The air filter is accessibly located in the cool zone in front of the radiator panels so it can easily be removed. Coarse dirt particles are extracted in the filter housing, further extending the cleaning interval.

Maintenance Overview	
Next maintenance in 10 hours	10 h
Next maintenance in 50 hours	38 h
Next maintenance in 100 hours	88 h
Next maintenance in 500 Hours	488 h
Next maintenance in 1000 hours	988 h

Maintenance counter in the CEBIS and CIS display



The front axle lubrication points are located in front of the radiator assembly for optimum accessibility



A lubrication chart under the bonnet simplifies maintenance



The battery is conveniently positioned above the right-hand access ladder



Whatever it takes.  
CLAAS Service & Parts.



CLAAS Service & Parts  
is there for you 24/7.  
[service.claas.com](http://service.claas.com)

Scan me.



**Safeguard your machine's reliability.**

Increase your operating reliability, minimise the risk of breakdown and repair. MAXI CARE offers you predictable costs. Create your own individual service package to meet your particular requirements.

**Remote Service.**

With Remote Service, all the relevant data from your telematics-equipped machines are made available to your service partner. This greatly simplifies the remote diagnostic process and the provision of remote support. Servicing can be carried out more efficiently and the level of machine readiness for use is enhanced. Remote Service is provided to you free of charge for a period of five years. All you have to do is give your consent.



**Specially matched to your machine.**

Precision-manufactured parts, high-quality consumables and useful accessories. Choose our comprehensive product range to be certain of receiving exactly the right solution to ensure 100% operating reliability for your machine.



**For your business: CLAAS FARM PARTS.**

CLAAS FARM PARTS offers one of the most comprehensive ranges of multi-brand parts and accessories for all agricultural applications on your farm.



**Global supply.**

The CLAAS Parts Logistics Center in Hamm, Germany, stocks almost 200,000 different parts and has a warehouse area of over 183,000 m<sup>2</sup>. This central spare parts warehouse delivers all ORIGINAL parts quickly and reliably all over the world.



**Your local CLAAS distributor.**

Wherever you are, you can count on us to always provide you with the service and the contact people you need. Your CLAAS partners are on hand in your local area, ready to support you and your machine around the clock. With know-how, experience, commitment and the best technical equipment. Whatever it takes.



These outstanding features speak for themselves.



#### CPS.

- FPT engines for high performance and low fuel consumption
- HEXASHIFT powershift transmission with HEXACTIV auto-shift function, cruise control and SMART STOP
- CMATIC continuously variable transmission available in CEBIS or CIS+ version
- Long wheelbase and balanced weight distribution
- Rear tyres up to 900 mm wide and 2.05 m in diameter
- Dual tyres at the rear with 2.5 m quick-release axle available in the AXION 850 and 870 for heavy traction work
- Choice of 540, 1000, 540 ECO or 1000 ECO PTO mode
- Up to seven spool valves and 205 l/min hydraulic capacity
- K80 ball hitch with up to 4 t drawbar load

#### Comfort and convenience.

- 4-pillar cab
- Three equipment options available: CEBIS, CIS+ or CIS
  - CMOTION multifunction control lever in the CEBIS version
  - Multifunction armrest with DRIVESTICK in the CIS+ and CIS version
- 4-point cab suspension
- Driver's seats with active suspension and ventilation
- PROACTIV front axle suspension
- Front and rear linkage with vibration damping
- Optimum accessibility and labelling for all maintenance points
- Drawer with toolbox built into the tractor
- GPS PILOT automatic steering and online task management via the CEMIS 1200 terminal
- CSM headland management
- CEMOS for tractors
- Implement management
- TELEMATICS
- ISOBUS implement control via the CEBIS or CEMIS 1200 terminal

AXION		870	850	830	810	800
<b>Dimensions and weights</b>						
Standard equipment						
Overall height (a)	mm	3215	3215	3215	3215	3215
Length: front linkage folded (b)	mm	5428	5428	5428	5428	5428
Wheelbase (c)	mm	2980	2980	2980	2980	2980
Ground clearance, front axle (d)	mm	470	470	470	470	470
Ground clearance, rear axle (e)	mm	526	526	526	526	526
Weight	kg	9050 / 9450	8700 / 9450	8400 / 9150	8300 / 9050	8300 / 8600



Sales, service and support – our team is here to help.  
[contact.claas.com](https://www.claas.com/contact)





AXION		870	850	830	810	800
<b>Engine</b>						
Manufacturer		FPT	FPT	FPT	FPT	FPT
Number of cylinders		6	6	6	6	6
Cubic capacity	cm <sup>3</sup>	6728	6728	6728	6728	6728
Variable geometry turbo		●	●	●	●	●
Engine fan		VISCTRONIC	VISCTRONIC	VISCTRONIC	VISCTRONIC	Visco coupler
Rated output (ECE R 120) <sup>1</sup>	kW/hp	199/270	184/250	165/225	151/205	142/194
Max. output (ECE R 120) <sup>1</sup>	kW/hp	206/280	194/264	173/235	158/215	150/205
Max. output with CPM (ECE R 120) <sup>1</sup>	kW/hp	217/295	–	–	–	–
Rated output type approval value for HEXASHIFT models <sup>2</sup>	kW/hp	–	186/249	168/225	153/205	142/194
Rated output type approval value for CMATIC models <sup>2</sup>	kW/hp	209/280	192/257	179/240	168/225	–
Max. output type approval value for HEXASHIFT models <sup>2</sup>	kW/hp	–	194/260	175/235	161/216	150/205
Max. output type approval value for CMATIC models <sup>2</sup>	kW/hp	221/296	204/273	188/252	175/235	–
Max. torque	Nm	1276	1132	1016	941	896
Max. fuel tank capacity	l	455	455	455	455	455
Oil-change interval	h	600	600	600	600	600

#### CMATIC continuously variable transmission

REVERSHIFT clutchless reverser		●	●	●	●	●
Min. speed at rated engine speed	km/h	0.05	0.05	0.05	0.05	–
Max. speed	km/h	40/50	40/50	40/50	40/50	–

#### HEXASHIFT powershift transmission

Number of gears		–	24/24	24/24	24/24	24/24
Powershift speeds		–	6	6	6	6
Electronically controlled ranges		–	4	4	4	4
REVERSHIFT clutchless reverser		–	●	●	●	●
Min. speed at rated engine speed	km/h	–	1.69	1.69	1.66	1.64
Min. speed with creep gear at rated engine speed	km/h	–	0.44	0.47	0.45	0.45
Max. speed	km/h	–	40/50	40/50	40/50	40/50

#### Rear axle

Max. diameter of rear tyres	m	2.05	2.05	2.05	2.05	1.95
Widest rear tyres		900/60 R 38	900/60 R 38	900/60 R 38	900/60 R 38	710/70 R 38
Flanged axle		●	●	●	●	●
Quick-release axle 2.5 or 3.0 m wide		○	○	○	○	○
Automatic differential locks		●	●	●	●	●
Park lock		●	●	●	●	●
Oil-change interval	h	1200	1200	1200	1200	1200

#### PTO

External operation of engagement and emergency stop		●	●	●	●	●
540 / 1000		●	●	●	●	●
540 / 540 ECO / 1000		○	○	○	○	○
540 ECO / 1000 / 1000 ECO		○	○	○	○	○
PTO shaft stub: 1½" with 6 or 21 splines and 1¾" with 20 splines		□	□	□	□	□

#### Four-wheel drive front axle

Rigid front axle		●	●	●	●	●
PROACTIV suspended front axle		○	○	○	○	○
Automatic 4-wheel drive		●	●	●	●	●
Turning radius	m	5.31	5.31	5.31	5.31	5.31

AXION		870	850	830	810	800
<b>Hydraulics</b>						
Load-sensing hydraulics 110 l/min		●	●	●	●	●
Load-sensing hydraulics 150 l/min		○	○	○	○	○
Load-sensing hydraulics 205 l/min		○	○	○	○	○
Max. operating pressure	bar	200	200	200	200	200
Number of mechanical spool valves		–	3–4	3–4	3–4	3–4
Number of electronic spool valves		3-7	3-7	3-7	3-7	3-7
Two central electronic spool valves, operated from ELECTROPILOT		○	○	○	○	○
Flow rate control		●	●	●	●	●

#### Rear linkage

Max. lift capacity at ball ends	kg	10200	10200	9700	9700	9500
Continuous lift capacity at 610 mm	kg	6200	6200	6200	6200	6200
Vibration damping		●	●	●	●	●
External controls		●	●	●	●	●
Active wheel slip control		○	○	○	○	○

#### Front linkage

Lift capacity	t	4.7 / 5.9	4.7 / 5.9	4.7 / 5.9	4.7 / 5.9	4.7 / 5.9
Front PTO 1000 rpm		○	○	○	○	○
Vibration damping		●	●	●	●	●
Position control		○	○	○	○	○
External front linkage operation		○	○	○	○	○
Four additional hydraulic connections		○	○	○	○	○
External operation of additional connections		○	○	○	○	○
ISOBUS and trailer socket		○	○	○	○	○

#### Cab

CIS		–	●	●	●	●
CIS+		●	○	○	○	○
CEBIS version		○	○	○	○	○
4-point suspension		●	●	●	●	●
Multifunction armrest		●	●	●	●	●
Air conditioning		●	●	●	●	●
Automatic climate control		○	○	○	○	○
Passenger seat with integral cool box		●	●	●	●	●

#### Data management and operator assistance systems

CEMOS		○	○	○	○	○
CSM headland management		○	○	○	○	○
ISOBUS		○	○	○	○	○
GPS PILOT ready		○	○	○	○	○
GPS PILOT steering system		○	○	○	○	○
TELEMATICS		●	●	●	●	●
Remote Service		●	●	●	●	●

<sup>1</sup> Meets ISO TR 14396

<sup>2</sup> Performance data fit criteria for admissibility.





CLAAS UK  
Saxham  
Bury St. Edmunds  
Suffolk  
IP28 6QZ  
Tel 01284 763100  
claas.co.uk  
info-uk@claas.com